

Technical Guide

KIOSK PRINTER

SK1-21A

SK1-31A

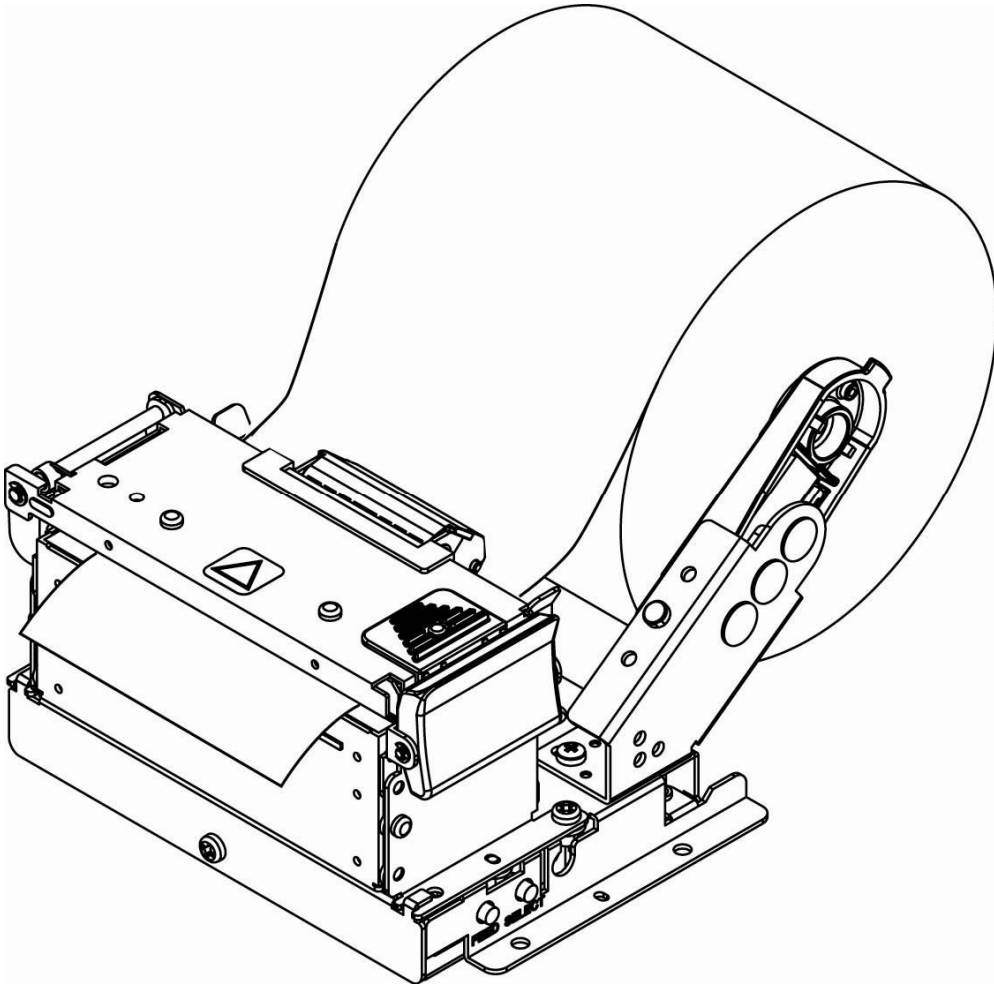

 **SANEI ELECTRIC INC.**

Rev4.6E



General notice

- * The specifications may be changed for product improvement without notice.
- * Updated information listed on our website. <http://www.sanei-elec.co.jp>
- * Sanei shall not be responsible for any damages attributable to incorrect operation, handling or improper operation environments, except those specified in this manual.
- * Sanei shall not be responsible for any claim of infringement or alleged infringement of patents, designs, trademarks, copyrights or other rights brought by a third party in relation to its products.
- * Operate this printer only in the manners as described in the Technical guide. Otherwise, accidents or problems could possibly occur.
- * Data are basically temporary; they cannot be stored or saved either for a long time or permanently. Please note that Sanei Electric shall not be responsible for any damages or lost profits resulting from the loss of data attributable to accidents, repairs, tests, and so on.
- * If you have any questions, or notice any clerical errors or omissions regarding the information in the technical guide, please contact your dealer.
- * Please note that Sanei Electric shall not be responsible for any results or effects resulting from operation of this Printer even if the information in the Technical guide.



Precautions

Symbol display

To use this equipment safely, or to protect the equipment from damage, the following symbols are used throughout this manual to highlight safety information



 Warning	The symbol indicates that failure to observe these instructions or mishandling of this equipment could lead to severe injury or death
 Caution	The symbol indicates that failure to observe these instructions or mishandling of this equipment could lead to injury or only property damage.

Samples of symbol

	The symbol indicates caution(including DANGER or WARNING).
	The symbol indicates the action is prohibited.
	The symbol indicates a required operation that must be performed.

When using the printer



	Do not subject the printer to strong shocks by dropping or hitting it.
	Avoid using the printer at the following location. It may cause failure. <ul style="list-style-type: none"> ◆ Locations with much dust, particles, water or oil. ◆ Locations with slanted surfaces or strong vibration. ◆ Locations with direct sunlight. near heating/warming equipments, or temperature over 60°C. ◆ Locations with temperatures of below -20°C, a relative humidity of 85%or more, dew condensation caused by extreme temperature change. ◆ Location with electromagnetic noise or corrosive gas.
	Do not touch the dot line on the thermal head and driver IC with metal and sandpaper etc. There is a possibility for damage of those parts.
	Do not touch the dot line on the thermal head with your fingers. The contamination may reduce the printing quality.
	Do not use the printer if there is condensation occurs on the thermal head. If the condensation occurs, keep the power off until condensation evaporates completely.
	Do not block the paper exit of the printer.
	Do not use a volatile chemical such as thinner or benzene.for maintenance work.



	Do not pull the paper end from the exit forcedly when the printer cover is closed.
	Turn off the printer power when trouble such as a paper jam occurs.
	Do not use loose paper. It may cause paper jam.
	Be careful of handling the thermal head to prevent heat elements and driver IC from exposure to static electricity.

When setting the printer

	The details such as the setting positions of the printer shall be referred to “3-7. Dimansions” Set the printer horizontally to the level, and make sure so the level not to be slanted.
---	---

Handling printer unit

 Warning	
	<ul style="list-style-type: none"> ◆ Never disassemble or repair the printer ,AC adapter or power cord by yourself. ◆ Do not use any AC adapter and power cord other than those specified. ◆ Do not bend the AC power cord or place heavy objects on it. Doing so may damage the cord and cause fire or electric shock. ◆ Never use a damaged AC power cord. It may cause fire or electric shock.
	<ul style="list-style-type: none"> ◆ Do not drop any metallic objects nor spill coffee,water or any other liquid. ◆ Do not use the printer in a places where it will be exposed to excess moisture or water spray. It may result in electric shock, short circuit and failure. ◆ Do not connect or disconnect the ACadapter with wet hands. It may result in electric shock, short circuit and failure.

 Caution	
	As the thermal head may be very hot immediately after printing, do not touch it to avoid burning your fingers. Be sure that the thermal head is cool before replacing a paper or cleaning the thermal head.
	Do not open the paper cover while printing.
	Do not pull the paper when the cover is closed.
	<ul style="list-style-type: none"> ◆ In the following cases, turn the printer power OFF and unplug the AC power cord from the outlet. <ul style="list-style-type: none"> • Smoke, unusual noises or odd smells are emittied by the printer. • When metallic objects is dropped or any liquid is spilled inside the printer. ◆ Continuous use may lead to printer failure,fire and electric shock. ◆ Make sure the fault does not continue and contact dealers for further assistance.
	If the printer is not to be used, turn the printer power OFF and leave the AC adapter disconnected from the outlet.

	<p>Remove the interface cable or AC adapter from the connector or the receptacle by gripping the connector or the AC plug. Never pull the cable itself.</p> <p>Doing so may damage the cable or adapter.</p>
--	--

Handling Paper Roll



	<p>Use the specified paper or equivalent. Use of other paper may reduce life of the thermal head and cause a decrease in printing quality Especially sodium(Na+), potassium(K+) and chlorine(Cl-) containing substances can remarkably reduce the life of the thermal head.</p>
	<p>Store the paper in a dry, cool and dark place.</p>
	<p>When pasting printed pages, use water-based glue. (starch glue, synthetic glue, etc.)</p>
	<p>The surface of thermal paper has been specially treated with a chemical agent to produce coloring by thermal chemical reaction.</p> <ul style="list-style-type: none"> ◆ Do not expose the paper for a long time under bright light. ◆ Avoid storing in high temperature, high humidity, damp area and direct sunlight. ◆ Do not rub the paper with hard objects. ◆ Keep the paper away from organic solvents. ◆ Do not let the paper touch vinyl chloride film, erasers or adhesive tapes for hours. ◆ Do not place the paper on diazo print paper or wet, freshly made paper copies. ◆ Do not touch the paper with wet hands. It may cause fingerprint to be marks on the paper or smudges.

Table of contents

1. General Outlines	8
1- 1. Product Outlines	8
1- 2. Features	8
1- 3. Classification.....	9
2. Handling Method	1 1
2- 1. Recommendable paper and printer options.....	1 1
2- 2. Appearance.....	1 2
2- 3. Inside Structures.....	1 3
2- 4. Setting Paper Roll	1 4
2- 5. Paper near-end sensor	1 5
2- 6. Changing 1-inch core adapter	1 6
2- 7. Adjust the paper position.....	1 6
2- 8. Clear paper jams	1 7
3. General specifications	1 8
3- 1. Specifications.....	1 8
3- 2. Sensor	2 0
3- 3. Printing area	2 1
3- 4. Print head and cutter position	2 1
3- 5. Paper sensor position	2 2
3- 6. Paper feeding	2 4
3- 7. Dimensions.....	2 5
4. Functions	2 9
4- 1. Self test printing.....	2 9
4- 2. HEX Dump mode.....	3 0

4- 3. Function setting mode	3 0
4- 4. Setting the memory switch	3 2
4- 5. Memory switch setting menue.....	3 3
4- 6. Adjusting printing density	3 5
4- 7. LED display	3 5
4- 8. Memory	3 7
5. Bezel Module	3 8
5- 1. Operating Mode.....	3 8
6. Presenter.....	3 9
6- 1. Specifications.....	3 9
6- 2. Operating Mode.....	3 9
6- 3. Stock space and Exit space.....	4 0
7. Interfaces	4 1
7- 1. USB.....	4 1
7- 2. Serial	4 2
7- 3. Power supply.....	4 4
8. Label print.....	4 5
9. Maintenance.....	4 9
9- 1. Maintenance	4 9
9- 2. Service for trouble shooting	5 0
10. Command systems	5 1
10- 1. Command table	5 1
10- 2. Data code table	5 4

1. General Outlines

1-1. Product Outlines

SK1-21(2-inch) & SK1-31(3-inch) are open frame printers equipped with Serial (RS232C) and USB interface. Super-compact design and robust body make it possible for installing limited space enclosures under wide range of operating environment. The reliable SK1 printers performing for versatile functions are ideal for a wide variety of kiosk systems.

1-2. Features

- **Small and Ultra-Light Weight**, Designed for wide variety of systems and equipments
- Max **200mm/sec** high-speed printing
- Variety of paper core holders (adjustable for half inch and 1-inch inner core roll)
- 1D and 2D (Option) Barcode printing
- Max **φ120mm** paper roll as standard
- Various Sensors built-in : Paper near end, Paper empty, Head open sensor, Black-Mark sensor (Option), Gap sensor (Option)
- Wide variety of paper size (58, 60, 80, 83mm)
- **Autoloading** function
- Selectable for **Partial cut** or **Full cut**
- Versatile operating environment
- Available for Windows driver, Utility Driver and Linux driver
- Available for **Remote Status Monitor**

<Other functions>

- Capable of HEX dump printing and self test printing.
- Various settings of characters, such as enlarged and upside down characters
- Adjustable for printing line space.
- Graphic printing by bit image.
- Downloaded characters and user-defined characters can be printed.
- Adjustable for paper feed amount.
- With Ruled Line command, table layouts can be easily printed.
- Page Mode allows erect/inverse images, clockwise 90 degrees/counterclockwise 90 degrees and overlapping printing.
- Page Mode allows setting the paper length to a maximum of 250mm.
- Using the Image Registration command, the printing layout can be set up beforehand.
- With the Printing Density command, the printing density can be changed.
- The command system conforms to ESC/POS™.
- Capable of registering print images in internal flash memory.

1- 3. Classification

The product is classified according to the Product Number as follows:

<3-inch Kiosk printer>

SK1-31 A S J 3 - 3 L Q B

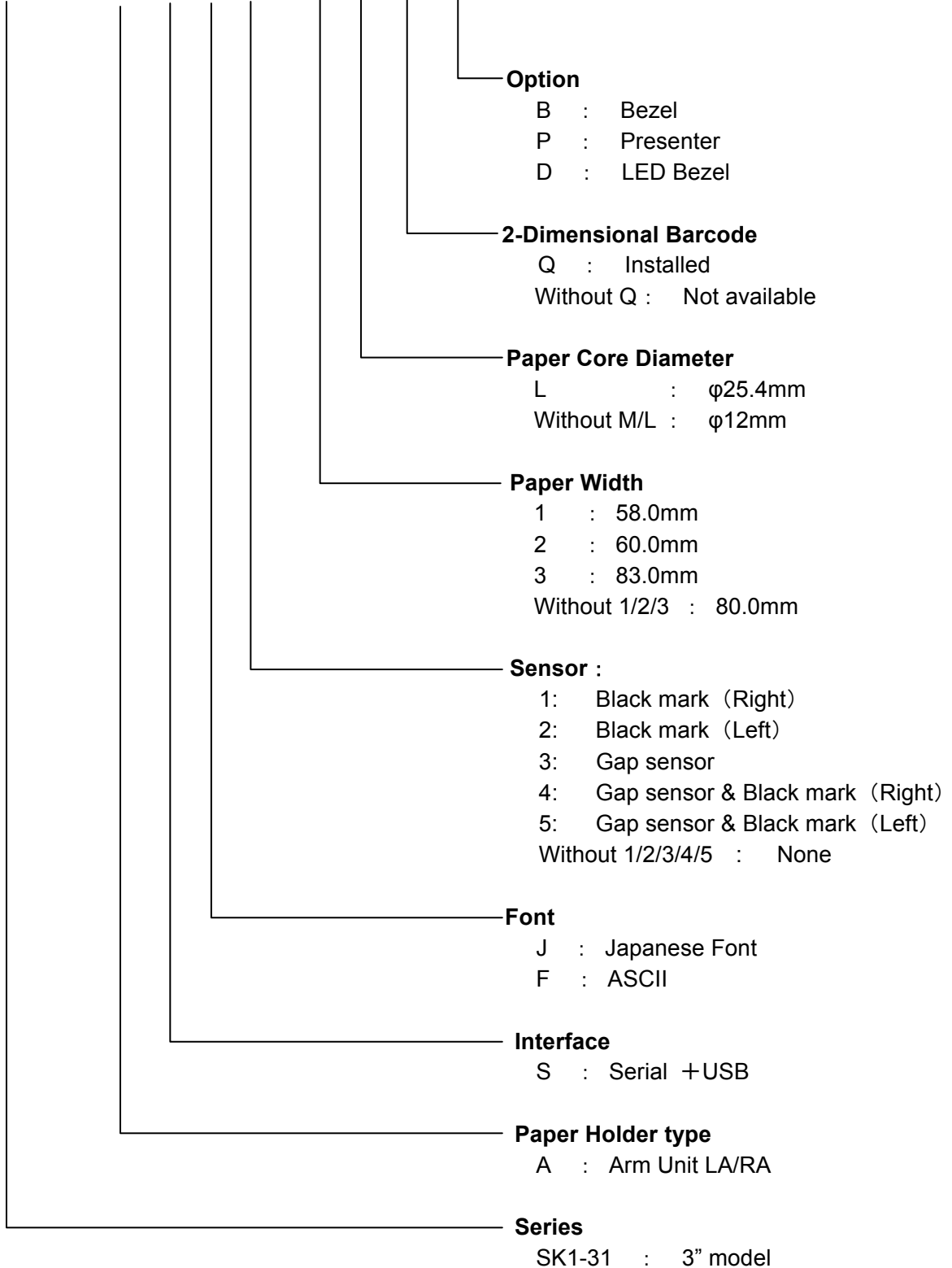

<2-inch Kiosk printer>

SK1-21 A S J 3 - 1 L Q B

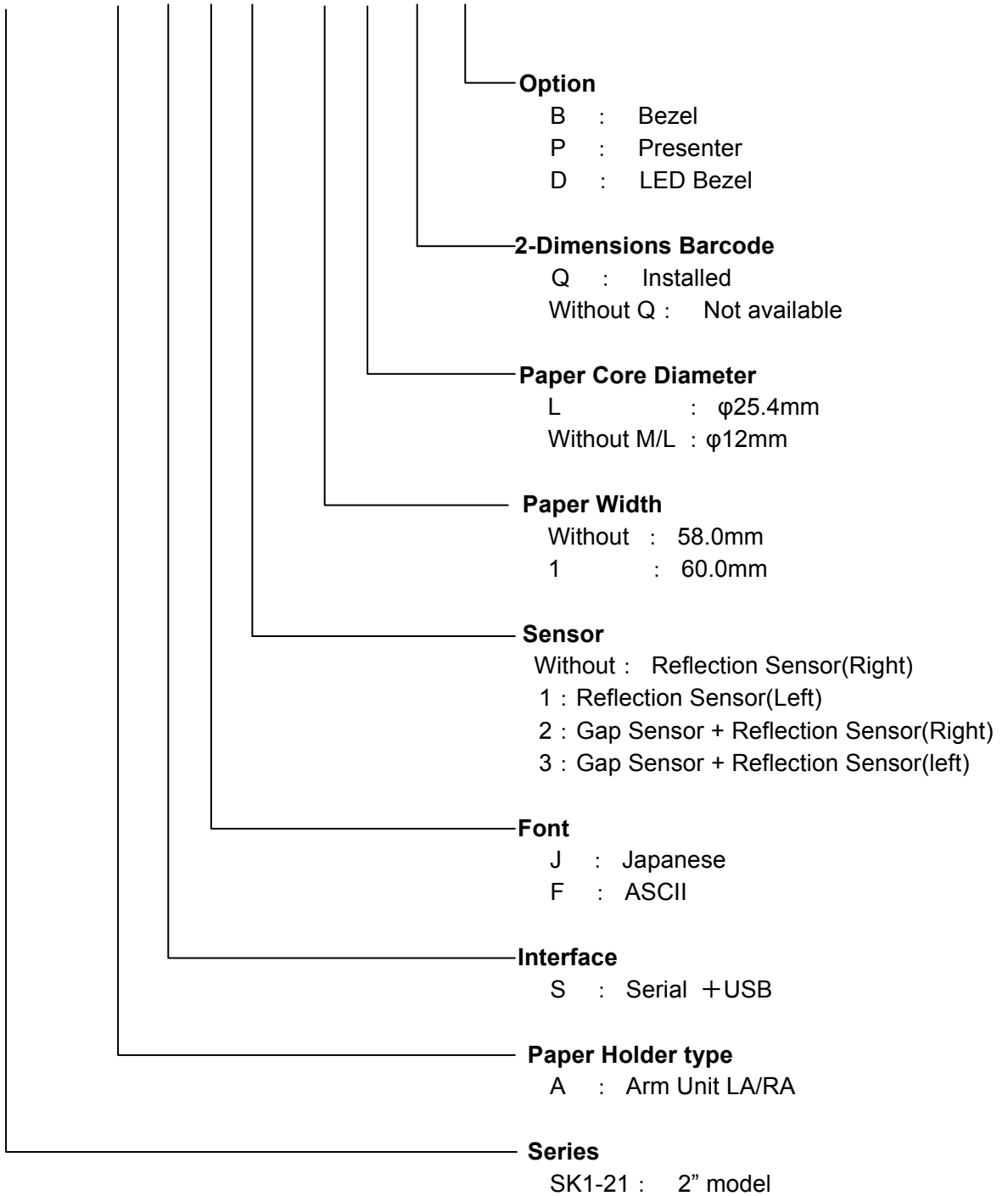

2. Handling Method

2-1. Recommendable paper and printer options

It is recommended to use the following paper for printing at SK1 Kiosk printers.
 (The paper roll can be purchased through the stores/shops you have purchase and the details of the paper information can be inquired to the stores/shops and/or distributors)

1. Recommendable paper

Specifications	Recommendable paper	
Part No.	TF50KS-E2D (Nippon Paper Industries)	
Sensitivity	Standard duration	
Paper width	57.5±0.5mm	79.5±0.5mm
Thickness	59µm	
Roll diameter	Φ120mm or less	
Core	Internal dia. Φ12×External dia.Φ18mm	
Thermal paper side	External	
Internal paper end	No adhesion · No fold	
External paper front	Cut straight and put a seal	
End mark	A red stripe on one side of the paper Width: 2 to 5mm Length: 500±100mm	

2. Printer options

It is available for the following options for SK1-21/31 Kiosk printers.

Option contents	Name	Specifications
Large paper holder	HL2-SK1	Paper holder for φ200mm diameter
Large paper holder	HL3-SK1	Paper holder for φ200mm diameter
1-inch Core adapter	BUSH 24.9	Attachment core holder for φ25.4mm diameter
Serial cable	CB-SK1-S4	Cross connection, approx 60cm, D-Sub9
DC cable	CB-SK1-D1	DC cable, approx 1m
USB cable	BLM-1.5U	USB cable, approx 1.5m
AC adapter	SA3-27A24O-1	Standard AC adapter (24V)

2- 2. Appearance

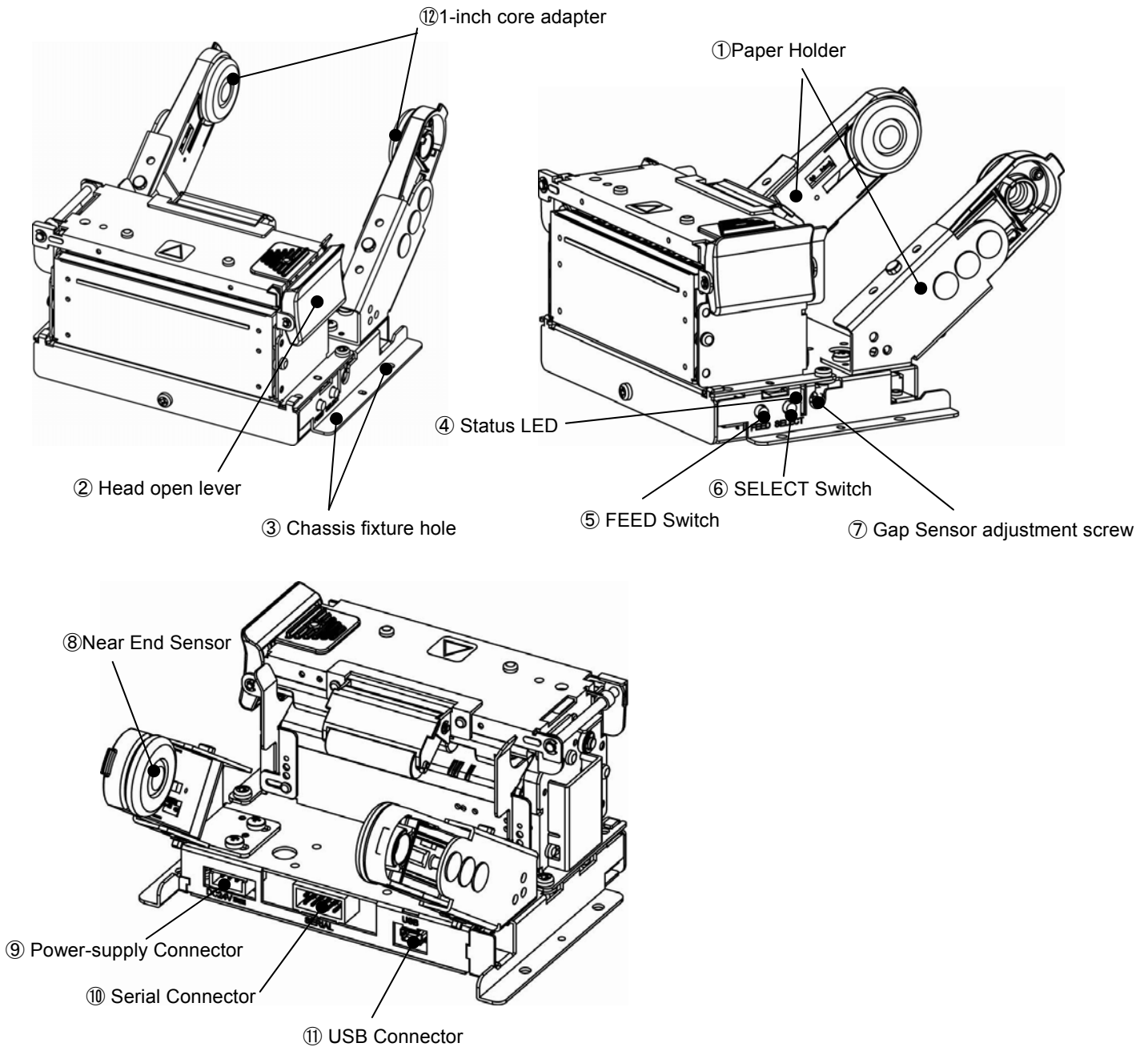

- | | |
|-------------------------------|---|
| ① Paper holder | : Φ 120mm paper roll is installed. |
| ② Head open lever | : Printer head is opened by side lever |
| ③ Chassis fixture hole | : Mounting the printer on screws |
| ④ Status LED | : Printer status is shown by LED ramp |
| ⑤ FEED Switch | : Feeding the paper |
| ⑥ SELECT Switch | : Use for setting the printer and printing HEX dump |
| ⑦ Gap sensor adjustment screw | : Adjust the sensitivity of label gap |
| ⑧ Near end sensor | : Detect paper near end |
| ⑨ Power supply connector | : for DC power supply |
| ⑩ Serial connector | : for Serial |
| ⑪ USB connector | : for USB |
| ⑫ 1-inch core adapter | : for 1-inch inner core of paper roll |
- The standard model is not installed core adapters.

2-3. Inside Structures

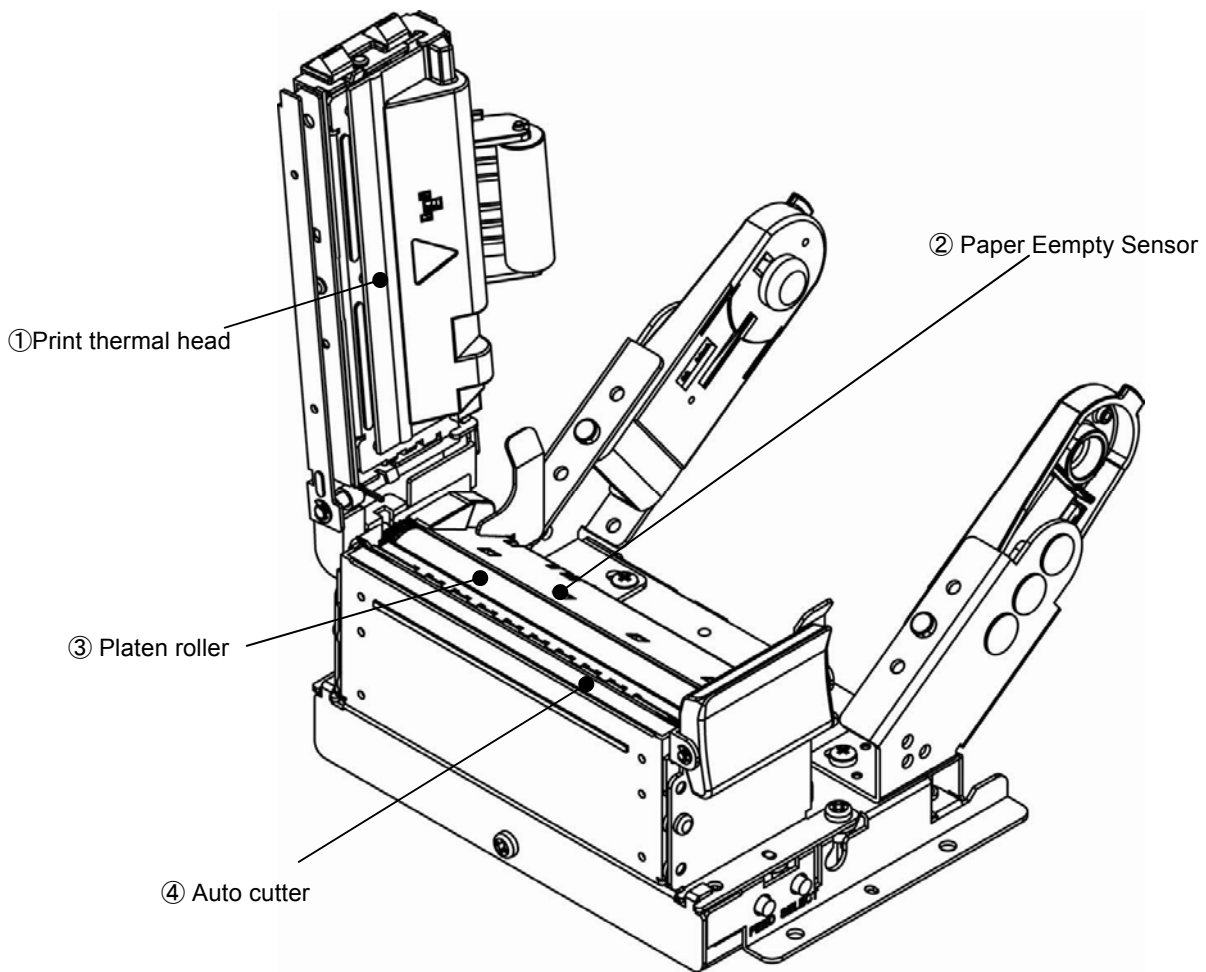

① Print thermal head

Print characters and graphics to thermal papers.

② Paper end sensor

Detect paper empty. If the sensor detects paper empty, the printer stops printing.

③ Platen roller

Feed the thermal paper on friction with the print head.

④ Auto cutter

Cut the thermal paper (Selectable for full cut or partial cut)

2-4. Setting Paper Roll

- ① Set a roll paper to paper holder.
Widening one side of paper holder and putting in the roll paper. Then setting the paper to holder.

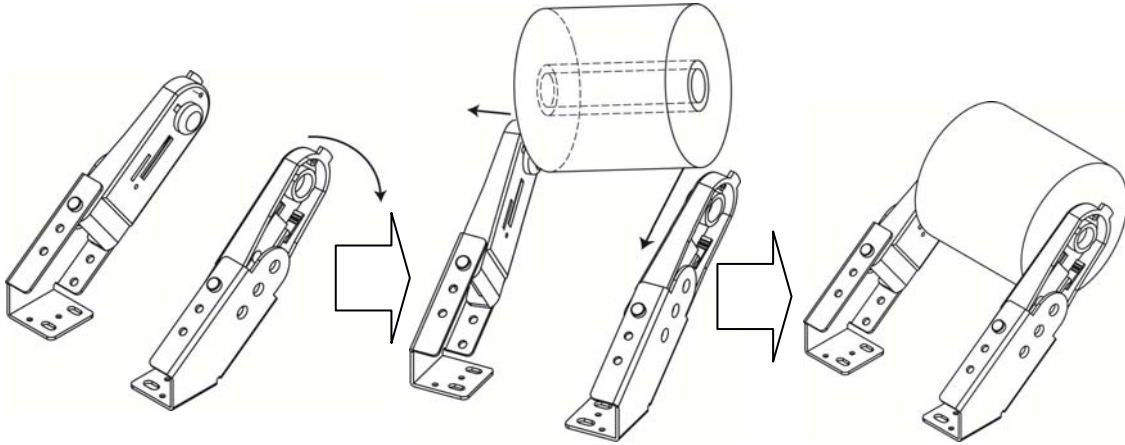

- ② Use head open lever
Press the head open lever to lift the head unit as shown in below.
Set the paper pulling out the paper end straightforward and close the head unit.

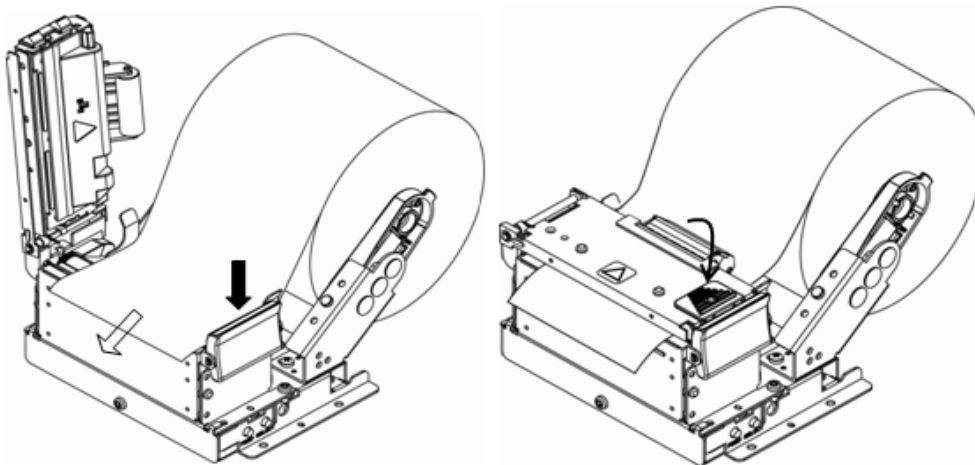

2. Auto-loading system

The paper is passed through thermal head as following, paper is set to feed automatically when the paper-empty sensor detects the paper.

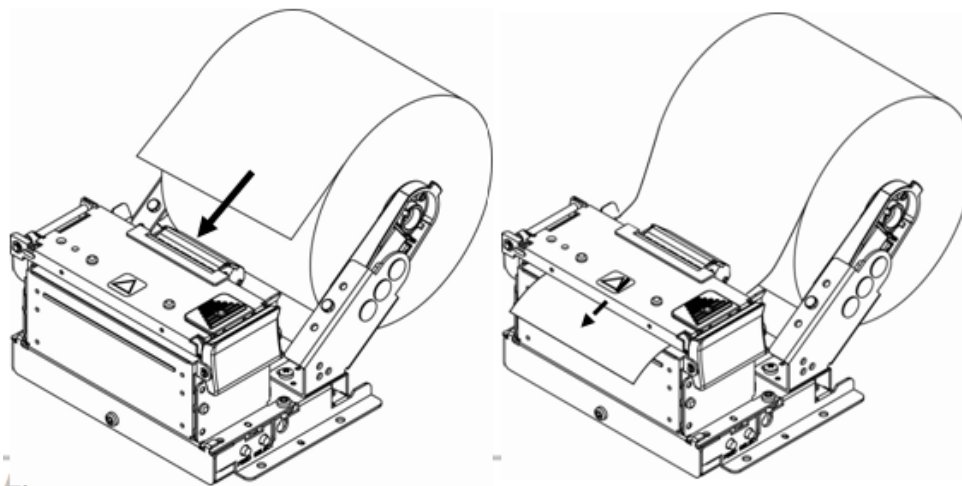

2- 5. Paper near-end sensor

Sensing roll paper's remaining amount can be adjusted in three levels by sliding near-end-sensor. The level is set based on core's diameter in factory default.

Adjusting knob on the holder must be slide in the direction of an arrow by using a fine-tipped tool like tweezers.

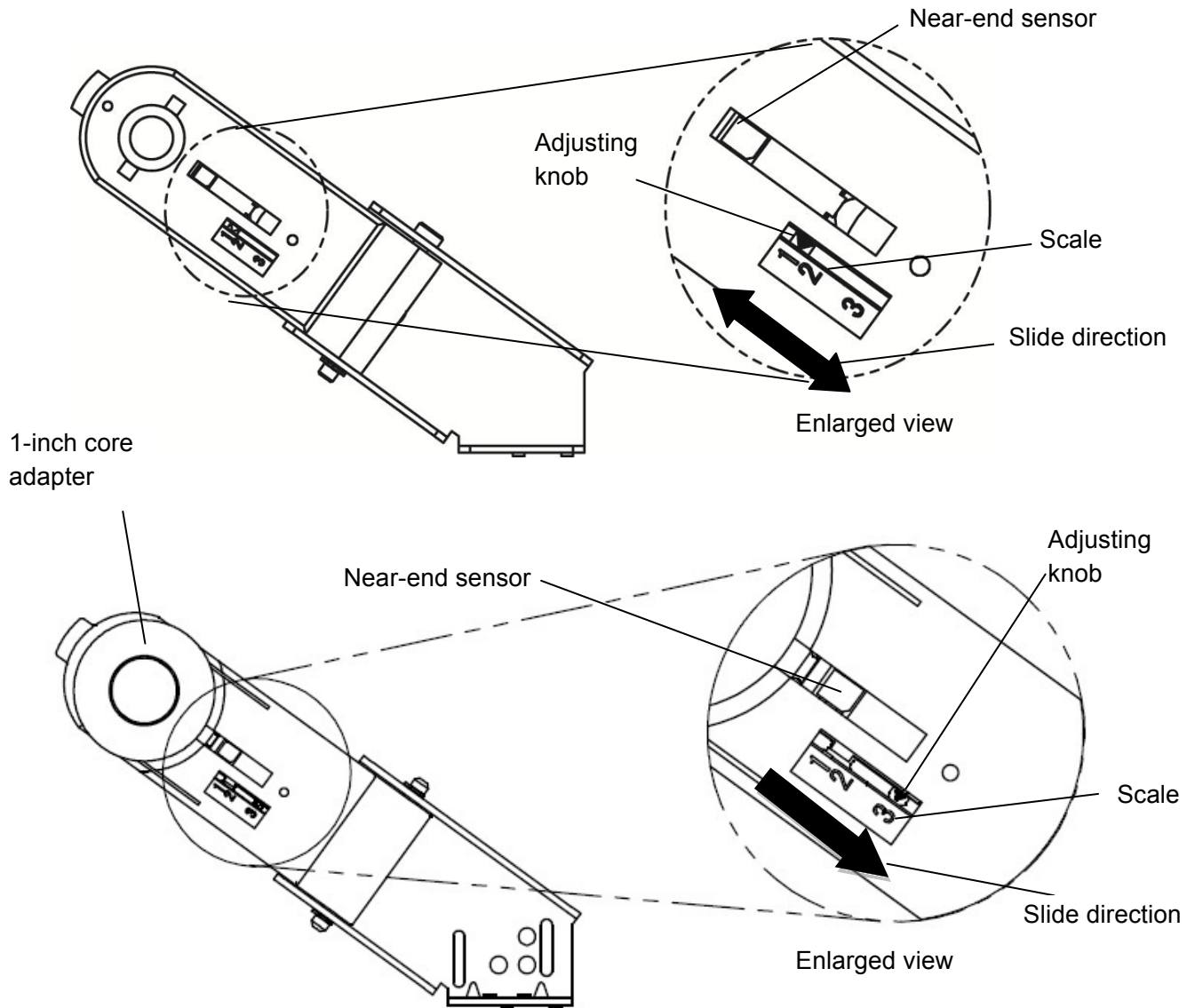

Adjusting Knob is set at No.3 when 1-inch core adapter is installed.

(Unit : mm)

Position	Detectable paper diameter
1	$\phi 21.0 \pm 2\text{mm}$
2	$\phi 24.5 \pm 2\text{mm}$
3	$\phi 35.0 \pm 2\text{mm}$

	<ul style="list-style-type: none"> • Do not mount the printer on vibrating or slanted surfaces. • The external diameter should be used as a reference value.
---	--

2- 6. Changing 1-inch core adapter

1. How to change 1-inch core adapter

Roll paper can be replaced by changing from standard $\phi 12\text{mm}$ to $\phi 25.4\text{mm}$.

1-1. How to attach the the attachment holders

Mount attachment holders to mounting holes.

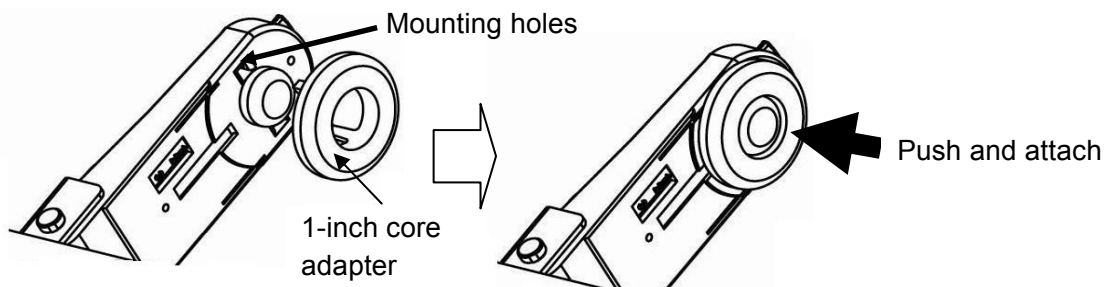

1-2. How to detach attachment holder

Clip the attachment holder and pull away in the direction of an arrow below.

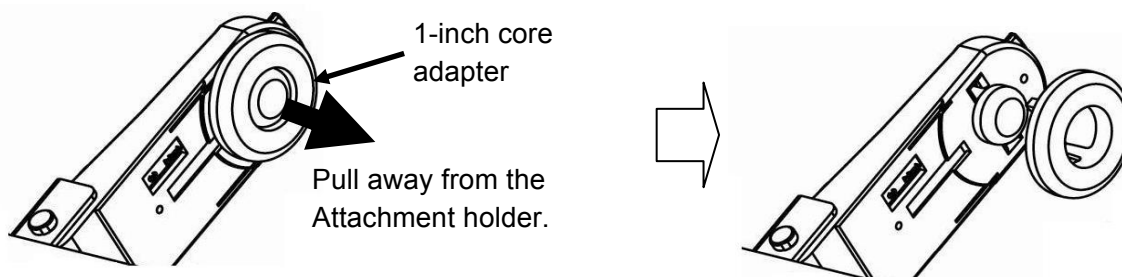

2- 7. Adjust the paper position

1. How to change the position of Holder arm.

Three types of roll paper ($\phi 120\text{mm}$, $\phi 102\text{mm}$, $\phi 83\text{mm}$ in diameter) is available by setting positoin of holder arms.

1-1. How to setting

Detach polyslider and pull out shaft, and then detach holder arm.

Next, put a spring on a projection and set the holder arm on the spring.

Finally, put the shaft and fix it by the polyslider.

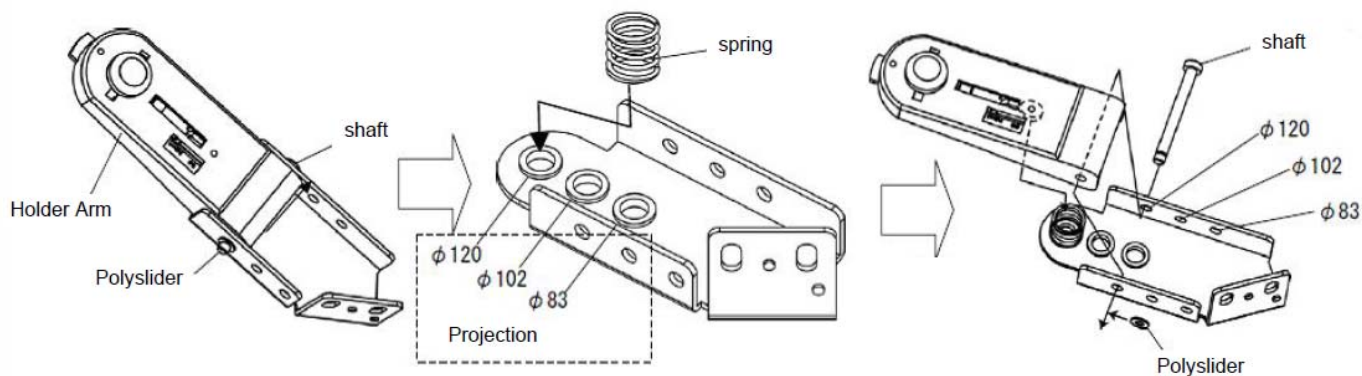

2- 8. Clear paper jams

1. First of all, turn OFF the printer power.
2. Press the head open lever to lift up the print head.
3. Remove the jammed paper.
4. Close the print head and turn ON the power.

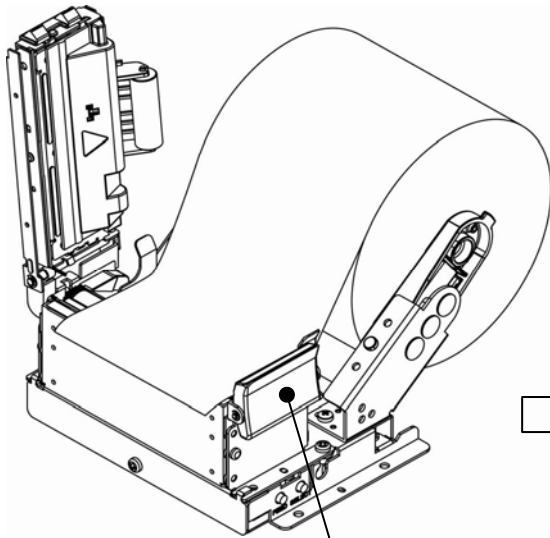

Press the head open lever to lift up the print head.

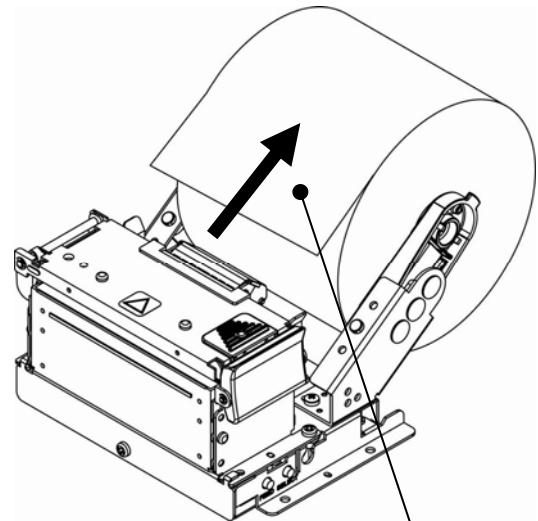

Remove the jammed paper



Turn the printer power OFF.
Don't put fingers into paper exit.

3. General specifications

3-1. Specifications

Model		SK1-31A	SK1-21A
Printing method		Direct line thermal	
Paper width		58/60/80/83mm	58/60mm
Print width		54/56/72/80mm	54/56mm
Number of dots		432/448/576/640dot	432/448dot
Resolution		8dot/mm(203dpi)	
Maximum printing speed		Max.200 mm/s *Note 1	
Paper holding method		Φ120mm paper holder	
Interface		Serial(Max.115.2kbps), USB2.0	
Charactors	ASC II	PC437/850/852/857/858/863/865/866/860/862/864/737 WPC1252/1252_2/1254/1250/1251 Square form of kana (the Japanese syllabary)	
	Download	available	
Font /Dots/ Lines	Printing Width	Printing Width : 54/56/72/80mm	
	ASC II 16 dots	8×16 dots(W×H) 54/56/72/80 lines	
	ASC II 24 dots	12×24 dots(W×H) 36/37/48/53 lines	
	Jfont 16 dots	16×16 dots(W×H) 27/28/36/40 lines	
	Jfont 24 dots	24×24dots(W×H) 18/18/24/26 lines	
Paper Sensors		Near end Sensor/Paper empty Sensor (OPTION) BM(Black mark) Sensor/Gap Sensor	Near end Sensor/Reflection Sensor (OPTION) Gap Sensor
Memory		Input buffer 8k bytes User memory, Non-volatile memory	
Logo registration		Download bit image	
Barcode		UPC-A/E, JAN13/8, CODE39, ITF, CODABAR, CODE128	
2D bar code (Option)		QR, MaxiCode, MicroPDF417, PDF417, DataMatrix	
Command systems		ESC/POS compatible *Note 2	
Setting position		Horizontal surface	
Regulation		VCCI, FCC, CE, CLASS A	
Printing life		Pulse activation 200million pulses or more Note3 Abrasion resistance 150Km or more	
Cutter life		Cutting life 1.5 million cuts or more (Thickness 75um or less)	
Power supply		DC Power supply DC 24V±5% / TYP 2.7A	
Current consumption		Standby : 70mA or less Printing : Average 2.5A *Note 3 (Peak 7.5A)	

Model	SK1-31A	SK1-21A																		
Operating environment	Temperature : -20°C to +60°C Humidity : 20%RH to 85%RH (No condensation) Printing quality is guaranteed from +5°C to +40°C																			
Guaranteed area of acceptable temperature and humidity <div style="text-align: center;"> </div>																				
Storage environment	Temperature : -30°C to +70°C Humidity : 10%RH to 90%RH (No condensation)																			
Weight	630g (Without paper roll)	525g (Without paper roll)																		
Dimensions (without protruding parts)	φ83mm	127×129.2×73.6mm(W×D×H)	104×129.2×73.6mm(W×D×H)																	
	φ102mm	127×137.3×79.5mm(W×D×H)	104×137.3×79.5mm(W×D×H)																	
	φ120mm	127×145.5×85.4mm(W×D×H)	104×145.5×85.4mm(W×D×H)																	
Paper roll	Paper width: 58 / 60 / 80 / 83 mm Note 4 & supplement Paper thickness : 59μm to 150μm (52g/m ² to 128g/m ²) External dimensions : φ120mm or less Core diameter : Internal/External dia. φ12.0mm/18mm Internal/External dia. φ25.4mm/31.4mm Standard of print density <table border="1" style="margin-left: 20px;"> <thead> <tr> <th>Part No.</th> <th>Thickness</th> <th>Print density</th> </tr> </thead> <tbody> <tr> <td>TF50KS-E2D</td> <td>59μm</td> <td>1.0</td> </tr> <tr> <td>TF11KS-ET</td> <td>145μm</td> <td>1.2</td> </tr> <tr> <td>P220AC</td> <td>105μm</td> <td>1.1</td> </tr> <tr> <td>PD160</td> <td>75μm</td> <td>1.05</td> </tr> <tr> <td>HP220A</td> <td>65μm</td> <td>1.0</td> </tr> </tbody> </table> Fan fold : The printer prints fan fold paper. For further information, please contact a local dealer.		Part No.	Thickness	Print density	TF50KS-E2D	59μm	1.0	TF11KS-ET	145μm	1.2	P220AC	105μm	1.1	PD160	75μm	1.05	HP220A	65μm	1.0
Part No.	Thickness	Print density																		
TF50KS-E2D	59μm	1.0																		
TF11KS-ET	145μm	1.2																		
P220AC	105μm	1.1																		
PD160	75μm	1.05																		
HP220A	65μm	1.0																		

*Note1 : Use AC adapter, printing rate less than 25%.

*Note2 : ESC/POS is registered trademark of Seiko Epson Corporation.

*Note3 : DC24.0V, Printing rate 12.5%, at room temperature

*Note4 : Not permitted with the smaller width paper roll.

Friction between the head and the platen roll in the no paper area may degrade print quality.

3-2. Sensor

(1) Paper-end sensor

The paper-end sensor is installed into the paper path and the photo-interrupter detects the existence of paper in the printer. When the paper runs out, the red LED lights and the printer goes into error mode and stops in the printing process.

After the paper is replaced, the printer resumes printing.



- Once the paper end sensor sends the paper empty signal, the printer stops printing.
- As soon as the paper end strip appears, replace the paper roll.

(2) Head open sensor

The head open sensor detects whether the print head is open or closed. Once the sensor detects the head open signal, the printer stops printing and goes OFF-Line, the Error LED lights Red. The printer resumes printing after the head is closed.

(3) Thermistor

The thermistor built in the print head detects the temperature of the print head.

If printing at a high printing rate for a long time, the print head temperature rises and the head may become overheated. To prevent overheating, the printer stops printing when the temperature is beyond a certain level, and blinks the red Error LED.

3- 3. Printing area

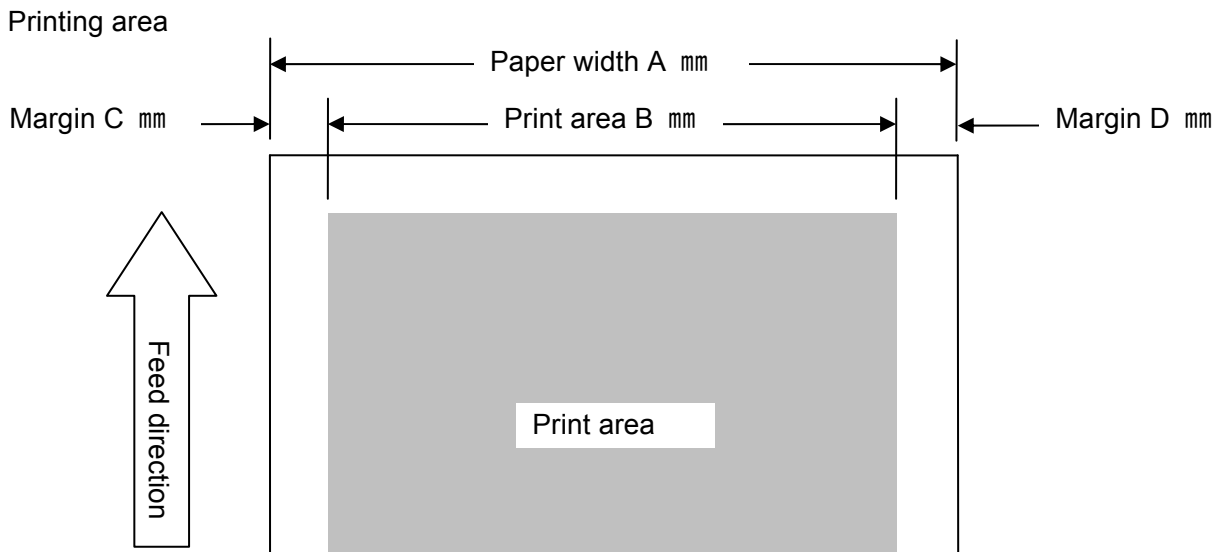

Paper width/Printing width	A	B	C	D
58mm /54mm	58	54	2	2
60mm / 56mm	60	56	2	2
80mm / 72mm	80	72	4	4
83mm / 80mm	83	80	0	3

 The left and right margins are approximate distance from paper edge and will shift about ± 1 mm depending on the paper path, paper position and tolerances.

3- 4. Print head and cutter position

Print head and cutter position

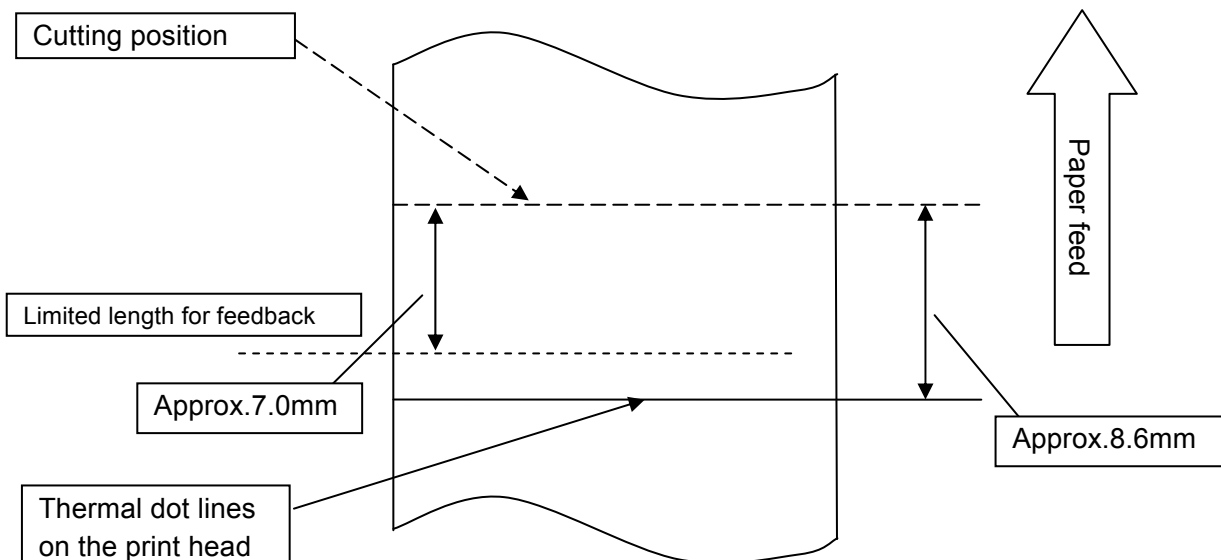

- The numeric values in the figure are nominal center values. Leave enough margin for the cutting position to account for paper flex or variability.
- The position of partial cut is varied by paper width.
- Partial cut is designed to keep the paper at the center of 80mm(SK1-31) or 58mm(SK1-21) paper.

3- 5. Paper sensor position

■SK1-31

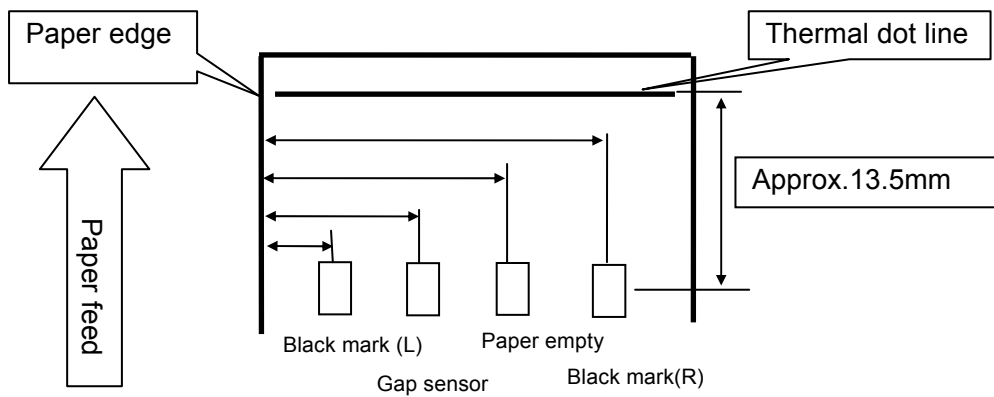
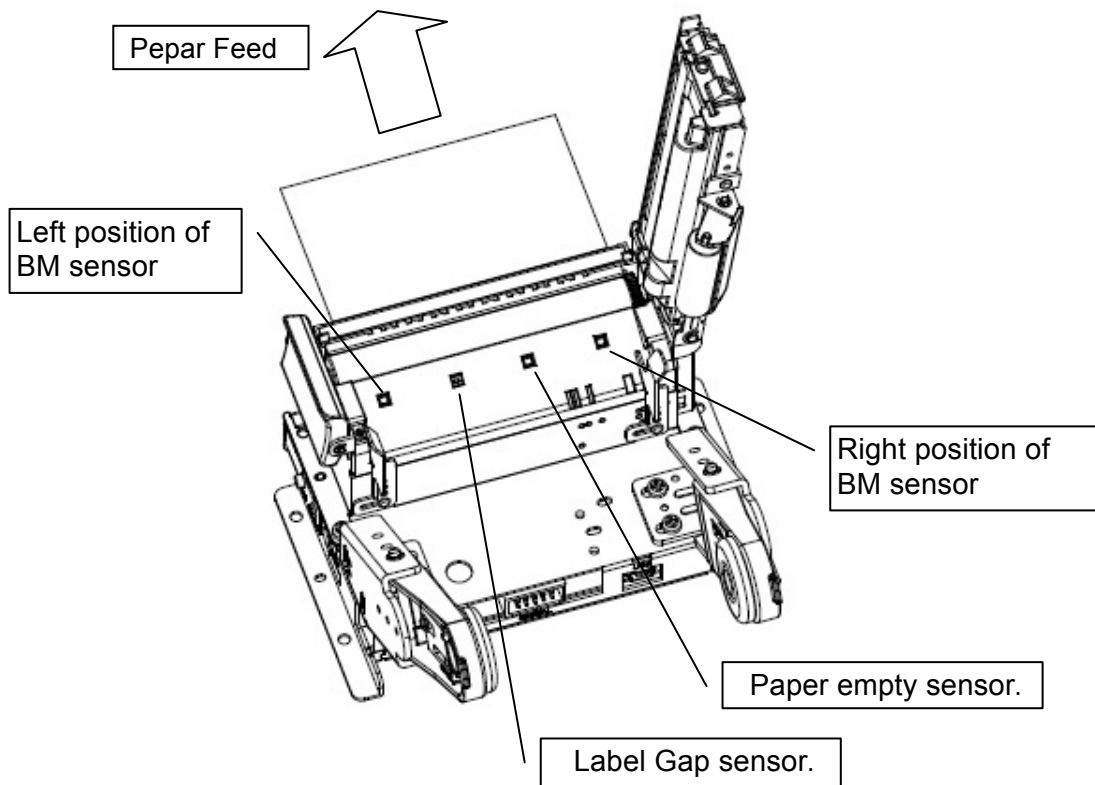

Sensor	Distance from paper edge (±1.0mm)
Black mark (Left) Note1,2,3	7.3mm
Gap sensor Note1	29.0mm
Paper empty	50.2mm
Black mark (Right) Note 1,2,3	72.0mm

Note1: Black mark sensor and gap sensor are embedded in the factory as options.

Note2: Choose the position of Black mark sensor either (L) or (R).

Note3: Black mark on reverse of thermal paper is sensed.

■SK1-21

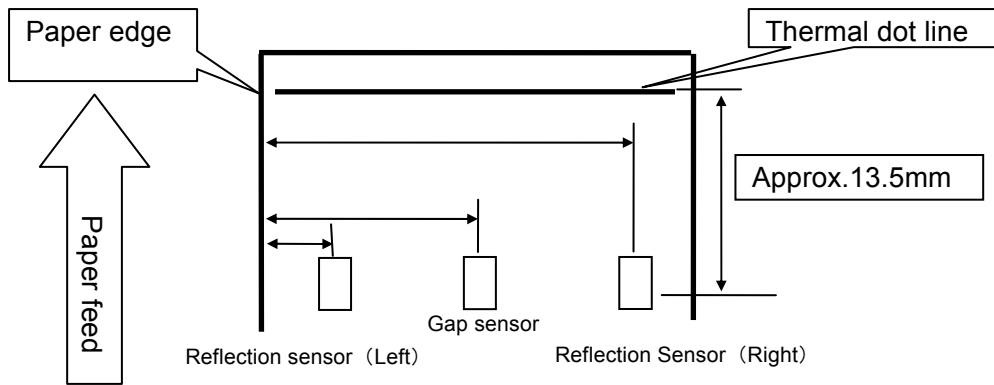
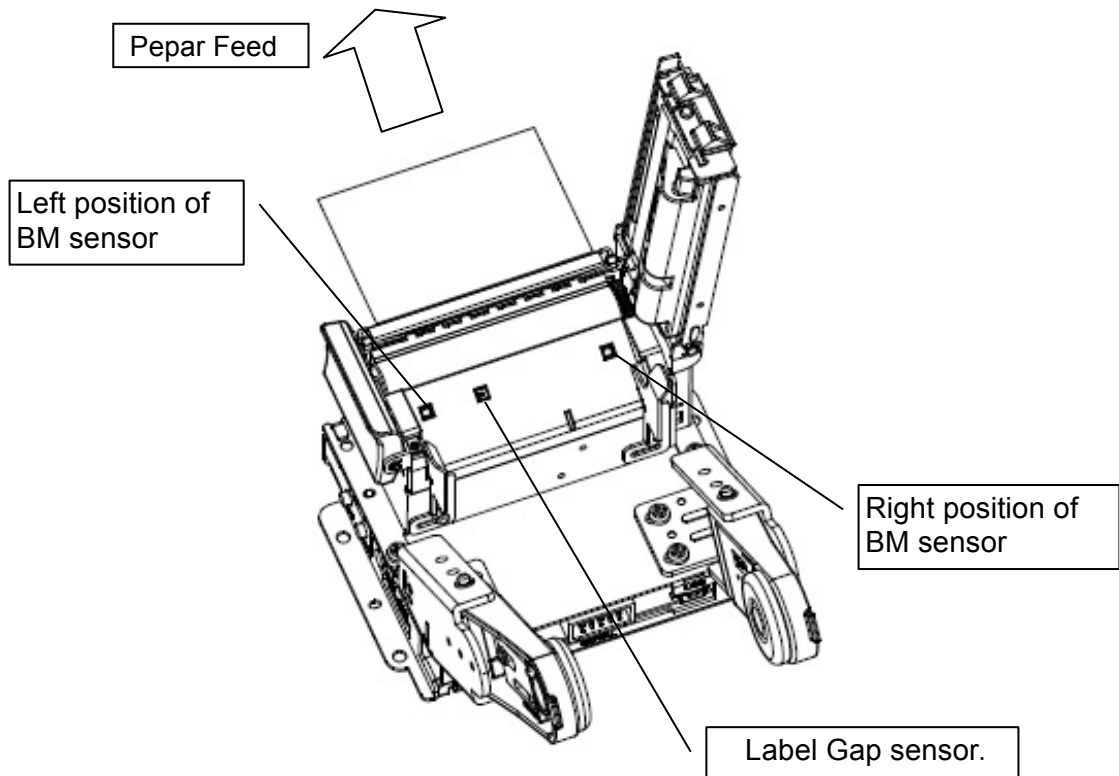

Sensor	Distance from paper edge (±1.0mm)
Reflection sensor (Left)	4.2mm
Gap sensor	19.3mm
Reflection sensor (Right)	54.2mm

Note1: Black mark sensor and gap sensor are embedded in the factory as options.

Note2: Black mark on reverse of thermal paper is sensed.

3- 6. Paper feeding

(1) Avoid deterioration by backlash feeding

Backlash in the paper feed mechanism may lead to under feeding and crowding of characters on adjacent lines. Be sure to always turn the paper feed motor 241 steps (3mm) at the start printing and initialization, and after opening and closing the thermal head.

(2) Notice on graphic printing

If the printer must wait for data from host systems while printing, it will temporarily stop printing and feeding paper. After the printer receives new data and resumes printing, the paper feeding of 1 to 3 lines may become irregular, especially if it is printing a bit image. In graphic printing, you may see irregular printing if the single lines of data are specified for Raster bit images. Specify a minimum of 16 lines or more when graphic data is printed.

(3) About paper cut

To prevent the printer from paper jam, the printer automatically feeds the paper about 1mm after cutting process. Therefore printing position is added 1mm to cutting position

3-7. Dimensions

External dimensions (Unit : mm)

SK1-31 with paper ϕ 102mm

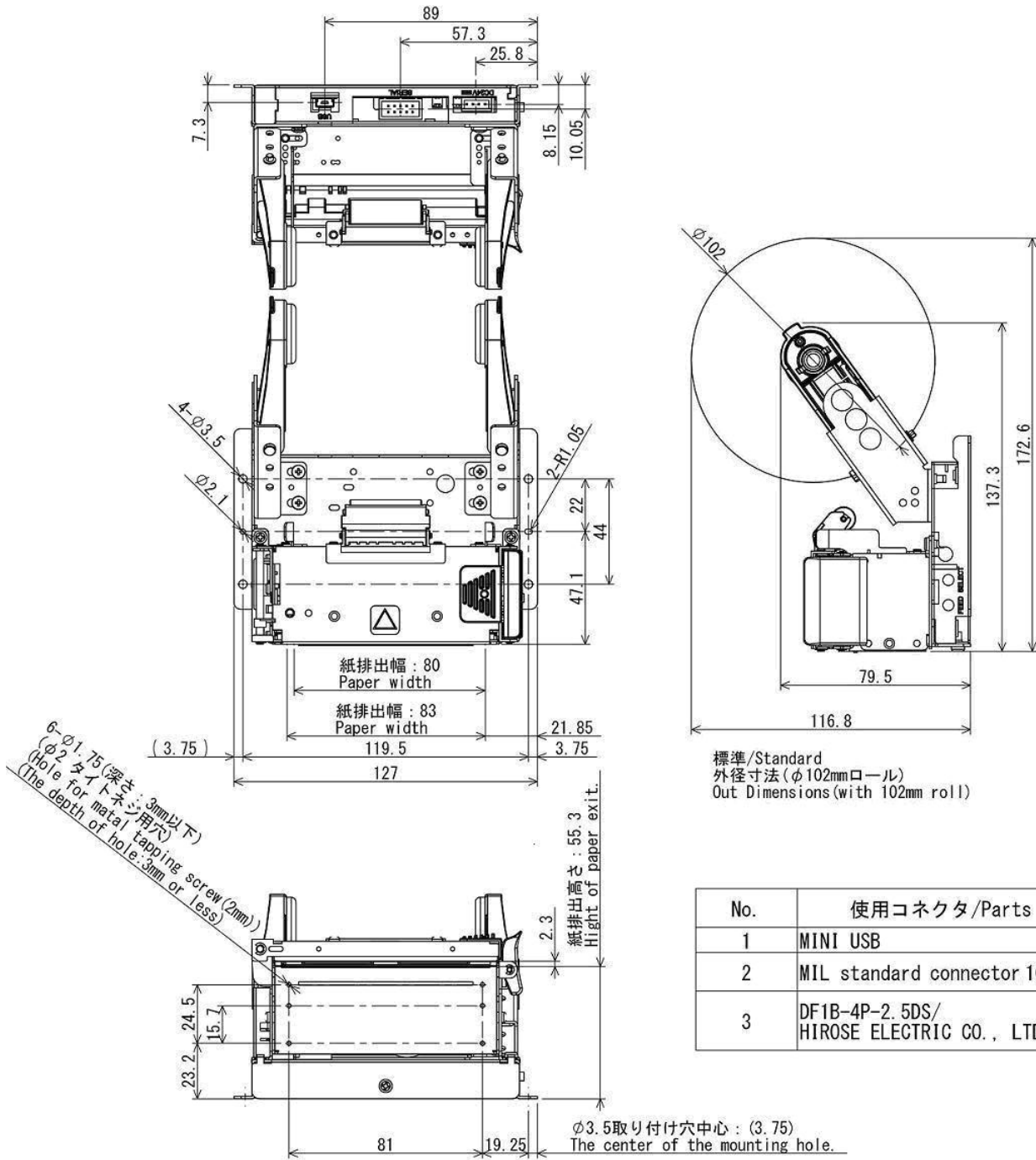

No.	使用コネクタ/Parts
1	MINI USB
2	MIL standard connector 10P
3	DF1B-4P-2.5DS/ HIROSE ELECTRIC CO., LTD

SK1-31 with paper $\phi 83\text{mm} / \phi 120\text{mm}$

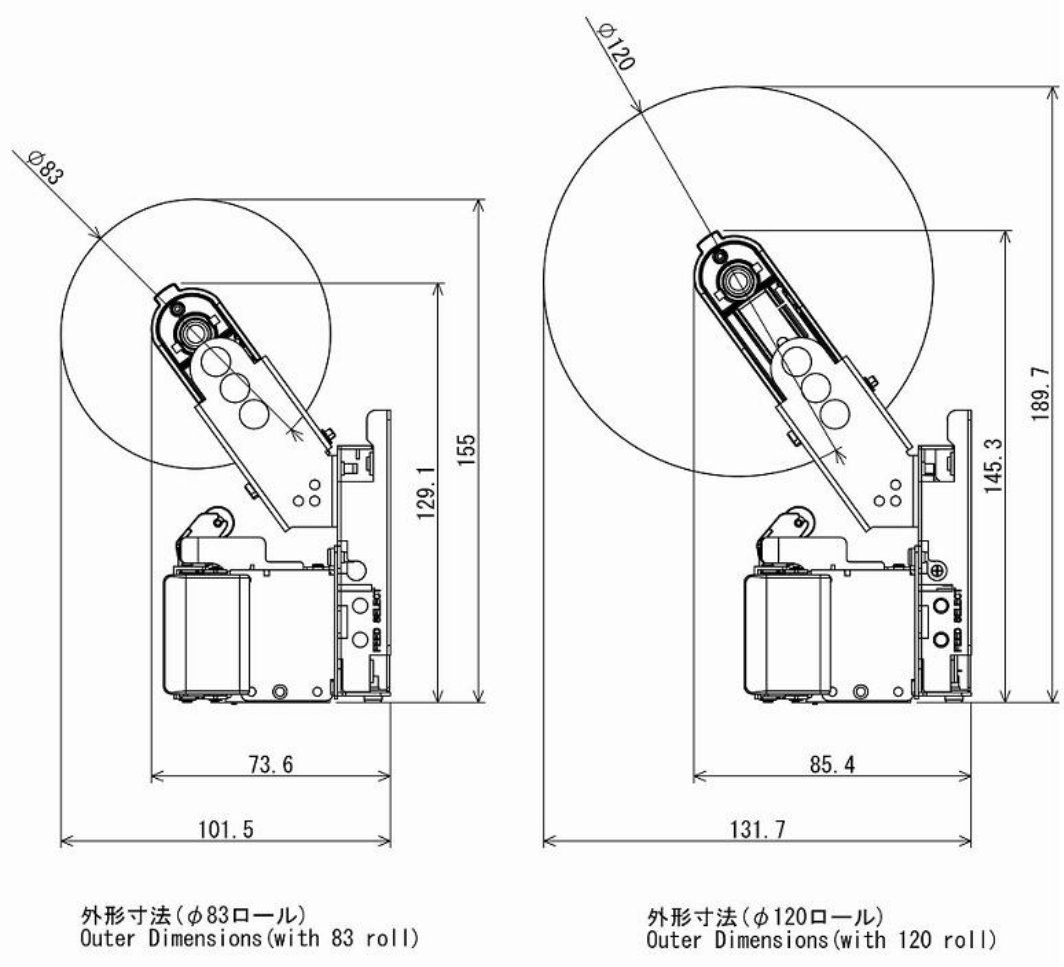

SK1-21 with paper ϕ 102mm

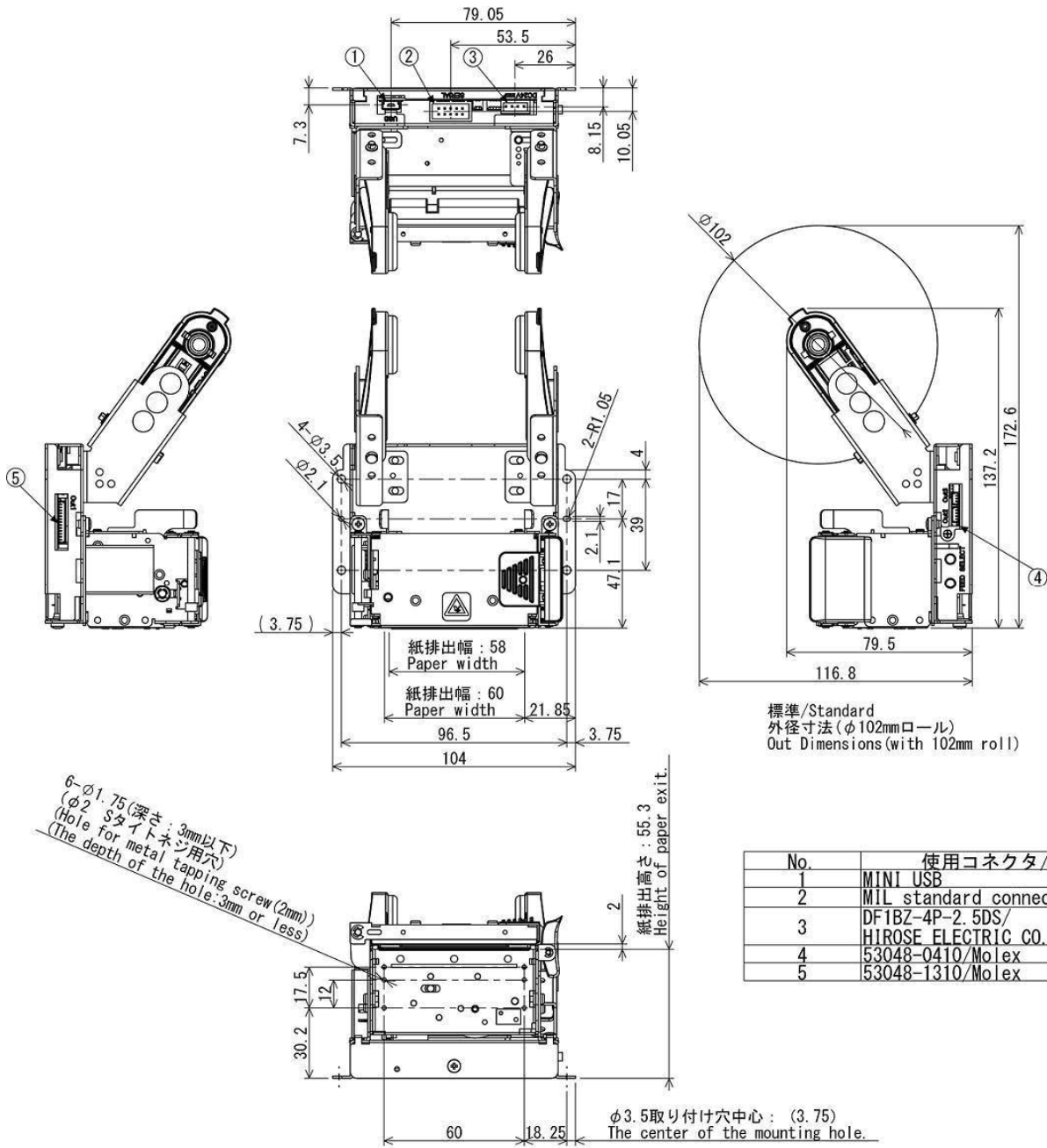

No.	使用コネクタ/Parts
1	MINI USB
2	MIL standard connector 10p
3	DF1BZ-4P-2.5DS/ HIROSE ELECTRIC CO., LTD.
4	53048-0410/Molex
5	53048-1310/Molex

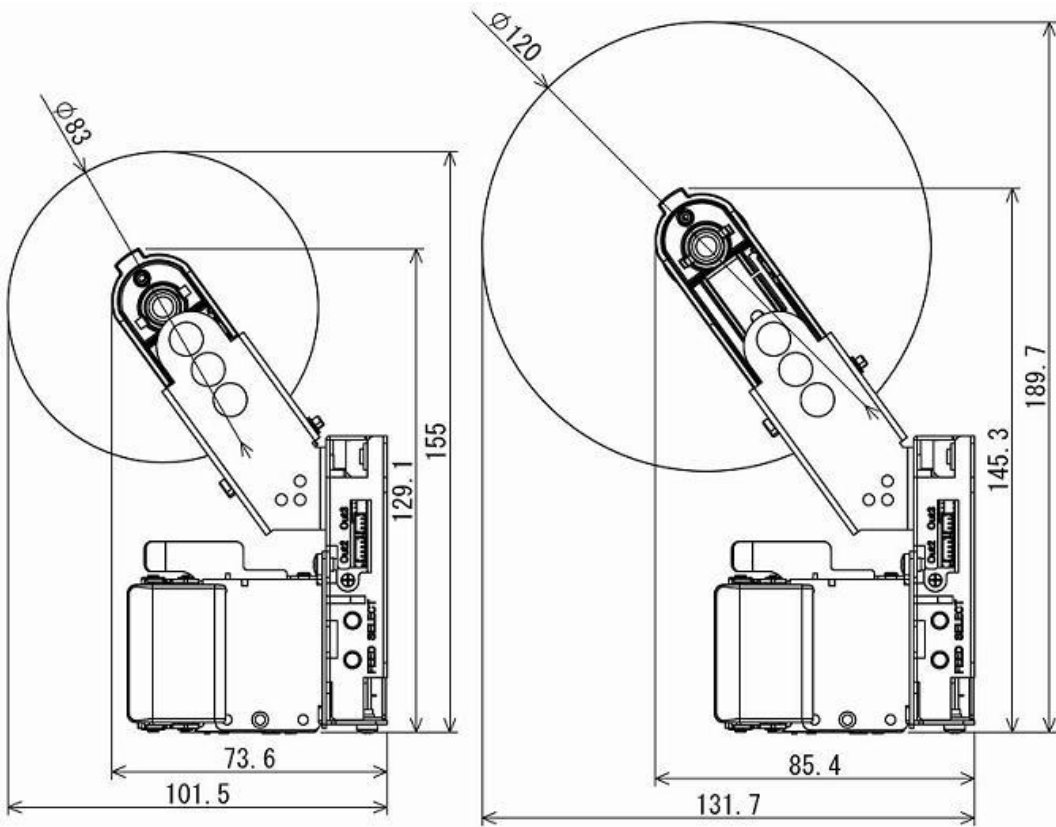

外径寸法 (ϕ 83mmロール)
Out Dimensions (with 83mm roll)

外径寸法 (ϕ 120mmロール)
Out Dimensions (with 120mm roll)

4. Functions

4-1. Self test printing

The printer prints characters and barcodes at self test printing.

- Printing method

- ① Turn ON the power switch while pressing the FEED switch.
- ② When the LED lights up and the printer starts printing, release the FEED button.
- ③ After completing the self test printing, the printer goes to Standby mode.

[Printing samples]

SK1-31S (A0)
Ver 1.00

TEST PRINT

!"#\$%&'()*+,-./0123456789:;<=>?@ABCDEFGHIJKLM
NOPQRSTUVWXYZ[¥]^_`abcdefghijklmnopqrstuvwxyz{
|}~
おやこっアイエオカキクココサシセソタチツテトニヌノハヒフホマミムメモヤユヨリ
ルロワヅ°=≡▲▼◆▼◆●○/X四片用崎分能行極神し

!"#\$%&'()*+,-./0123456
789:;<=>?@ABCDEFGHIJKLM
NOPQRSTUVWXYZ[¥]^_`abcd
efghijklmnopqrstuvwxyz{
|}~

ABCDEFGHIJKL

ABCDEFGHIJKL

ABCDEFGHIJKL

ABCDEFGHIJKL

ABCDEFGHIJKL

ABCDEFGHIJKL



4- 2. HEX Dump mode

Data entered from the computer is printed in hexadecimal numbers and characters.

● Printing method

- ① With pressing the SELECT button, turn on the power switch.
- ② When the LED lights up and printer starts printing, release the SELECT button.
- ③ After printing the following “HEX DUMP MODE”, starts Hexadecimal mode.
- ④ Prints hexadecimal numbers and characters entered from the host system.
- ⑤ Press the power switch to cancel the HEX dump mode.

[Example]

[HEX DUMP MODE]

```
20 21 22 23 24 25 26 27  !"#$%&'
28 29 2A 2B 2C 2D 2E 2F  ()*+, -./
30 31 32 33 34 35 36 37  01234567
38 39 3A 3B 3C 3D 3E 3F  89:;<=>?
40 41 42 43 44 45 46 47  @ABCDEFG
48 49 4A 4B 4C 4D 4E 4F  HIJKLMNO
50 51 52 53 54 55 56 57  PQRSTUWV
58 59 5A 5B 5C 5D 5E 5F  XYZ[^\_
60 61 62 63 64 65 66 67  `abcdefg
68 69 6A 6B 6C 6D 6E 6F  hijklmno
70 71 72 73 74 75 76 77  pqrstuvwxyz
78 79 7A 7B 7C 7D 7E 7F  xyz{|}~.
```

4- 3. Function setting mode

There is a function setting mode to switch register functions in the memory manually. Functions are called up by the SELECT and FEED buttons and the printer prints registered functions.

(1) About memory switching

The memory switch is classified as follows.

- ① **COMMON SETTING** : Common functions
- ② **INTERFACE SETTING** : Basic interface functions

(2) Function setting method

1. While pressing the FEED/SELECT button, turn ON the power switch.
2. When the LED lights up and printing starts, release the button.
3. The printer prints out the current setting mode and returns to that function setting.
4. To change the current function setting, press the feed button.
5. Refer to setting flow chart in “Setting of memory switch.”

<p>---COMMON SETTING---</p> <p>PAPER FEED = OFF</p> <p>OFFLINE BUSY = ON</p> <p>SELECT SENSOR = Reflection</p> <p>MARK DETECTION = OFF</p> <p>MARK RE-DETECTION = OFF</p> <p>CHARACTER TABLE = PC437</p> <p>PRINT DENSITY = 100%</p> <p>PRINT WIDTH = 80/72</p> <p>MECHANISM SPEED = 200mm/s</p> <p>SELECT NEAR-END = ON</p> <p>CUT AFTER FEED-SW = NON-CUT</p> <p>USB DEVICE CLASS = PRINTER</p> <p>USB PORT NUMBER = NON</p> <p>COMMAND MODE = MODE-A</p> <p>BEZEL MODE = NON</p> <p>SELECT REELER = OFF</p> <p>PRESENTER MODE = CLAMP/RETRACT</p> <p>Act. For Driver = INVALID</p>	<p>Common functions</p>
<p>---INTERFACE SETTING---</p> <p>BAUD RATE = 115200bps</p> <p>BIT LENGTH = 8Bit</p> <p>PARITY = Non</p> <p>BUSY CONTROL = RTS/CTS</p> <p>CTS AVAILABLE = INVALID</p>	<p>Basic interface functions</p>
<p>---MEMORY SWITCH---</p> <p>0x00 0x20 0x28 0x07 0x1E 0x00</p> <p>0x3C 0x04 0x00 0x00</p> <p>Serial ID = Non Data</p>	<p>Current memory switch by HEX mode (Lead from DC2K command)</p>
<p>---CURRENT VOLTAGE---</p> <p>24.0V</p>	<p>Current supply voltage</p>
<p>---SENSOR---</p> <p>Reflection = 0.8V</p> <p>Transmission = 0.8V</p> <p>Bezel sensitivity = 2.0V</p>	<p>Mark sensor detection level (Threshold voltage)</p>

Table 2 Example

4- 4. Setting the memory switch

Follow the flow chart to change the parameter. As setting parameter is printed, choose the right parameter by manipulating the FEED and SELECT buttons.

After completing the parameters set up, data are stored and the printer goes to standby mode.

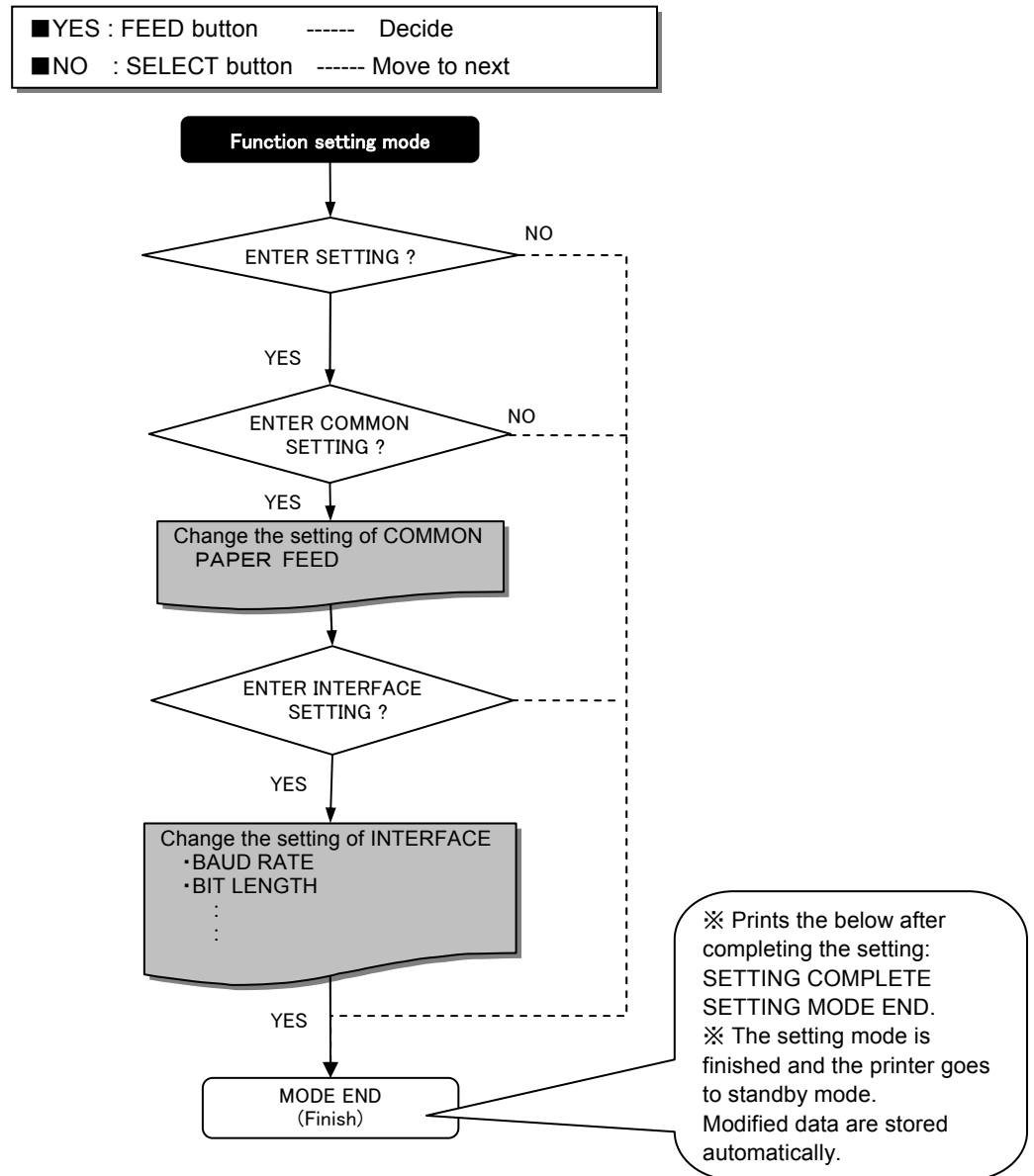

4- 5. Memory switch setting menu

(1) COMMON SETTING

Menu	Default	Value	Description
PAPER FEED	OFF	OFF ON(10mm) / ON(20mm) ON(30mm) / ON(40mm) ON(50mm) / ON(60mm)	Enable/disable paper feed after closing the print head. <ul style="list-style-type: none"> When paper feed is ON, the printer feed the paper as specified (Xmm) length after closing the print head and make full-cut after feeding the paper. When paper feed is OFF, the paper is not fed. The value is changeable using the DC2K command.
OFFLINE BUSY	ON	ON OFF	Enable/disable OFFLINE BUSY when an error occurs. <At selecting ON> <ul style="list-style-type: none"> The communication becomes OFF-LINE when an error occurs. The printer stops printing and maintained the receiving data until the error is cleared. <At selecting OFF> <ul style="list-style-type: none"> The communication becomes ON-LINE when an error occurs. Receiving data during an error are continuously processed and printing data are not stored. When bezel is used, this mode is selected.
SELECT SENSOR	Reflection	Reflection Transmission	Select the mark sensor for label printing. <ul style="list-style-type: none"> Reflection ··· Detected by Black mark sensor Transmission··· Detected by Gap sensor.
MARK DETECTION	OFF	OFF ON	Enable/disable the Black mark sensor/Gap sensor functions.
MARK RE-DETECTION	OFF	OFF ON	Enables/disables re-detecting function after the paper setting.
CHARACTER TABLE	PC437	KATAKANA PC437 / PC850 PC852 / PC857 PC858 / PC863 PC865 / PC866 WPC1252 / PC860 WPC1252_2 PC862 / PC864 WPC1254 / WPC1250 WPC1251 / PC737	Select the characters. <ul style="list-style-type: none"> - PC862 font was added after V1.87 - WPCXXXX font was added after V1.68 - PC864 font was added after V1.98 - PC737 font was added after V1.99
PRINT DENSITY	100%	80% / 90% 100% / 110% 120% / 130% 140% / 150%	Specify the printing density.
PRINT WIDTH	Comply with classified paper width	80/72 60/56 58/54 83/80	Select the paper width. (Printing width is set at the factory)
MECHANISM SPEED	200mm/s	110mm/s 130mm/s 150mm/s 170mm/s 190mm/s 200mm/s	Select maximum printing speed

Menu	Default	Value	Description
SELECT NEAR-END	ON	ON OFF	Select near end sensor ON ... activate sensor OFF ... cancel sensor
CUT AFTER FEED SW	NON-CUT	NON-CUT PARTIAL-CUT FULL-CUT	Select cutting operation after FEED switch is ON. * function added after V1.20
USB DEVICE CLASS	PRINTER	PRINTER COMMUNICATION	Selects device operation mode of USB * function added after V1.20
USB PORT NUMBER	NON	NON 1-9	Select USB Port Number · NON ... Selects arbitrary USB Serial ID · 1-9 ... Selects USB Serial ID 1-9 * function added after V1.91
COMMAND MODE	MODE-A	MODE-A MODE-B	Select command emmuation * function added after V1.20
BEZEL MODE	NON	NON MODE-A MODE-B MODE-C	Select bezel mode * function added after V1.30
SELECT REELER	OFF	OFF ON	Select reeler mode * function added after V1.51
PRESENTER MODE	CLAMP/ RETRACT	CLAMP/RETRACT CLAMP/EJECT CLAMP ONLY CONTINUOUS	Backward collecting operation Forward collecting operation Ejecting operation Continuous ejecting operation * function added after V1.89
Act. For Driver	INVALID	INVALID VALID	Set driver's activity. * function added after V1.99

(2) INTERFACE SETTING

Menu	Default	Value	Description
BAUD RATE	115200bps	1200bps 2400bps 4800bps 9600bps 19200bps 38400bps 57600bps 115200bps	Select the baud rate.
BIT LENGTH	8bit	8bit 7bit	Select the bit length of serial communication.
PARITY	Non	Non Odd Even	Select the parity of serial communication.
BUSY CONTROL	RTS/CTS	RTS/CTS Xon/Xoff	Select the flow control of serial communication.
CTS AVAILABLE	INVALID	INVALID VALID	Select the CTS signal of the serial communication INVALID . . . CTS signal is invalid. VALID . . . CTS signal is valid. * function added after V1.99

4- 6. Adjusting printing density

Paper sensitivity varies by type of thermal paper. Choose the right density to realize best printing quality and reliable printing. (The excess heating of the thermal head may cause the reduction of head life and contamination)

Allows setting density form 60 to 150%. The default value from the factory is 100% for maintaining proper printing quality. Details of the adjustment method are written in “Command systems DC2 ~ (Set print density).

Printing density

Part No.	Maker.	Density
TF50KS-E2D	Nippon Paper	100%
TF50KS-EY	Nippon Paper	100%
TF11KS-ET	Nippon Paper	120%
F230AA	Mitsubishi	100%
HP-220A	Mitsubishi	100%

4- 7. LED display

When an error occurs, the STATUS LED lights or blinks depending on the type of errors as follows.

1. No error signal is detected.

● Standby

It is possible to print and the printer waits for printing data by ONLINE.

● Initialization

Initialize printer memories. The printer goes OFFLINE during initialization and status LED blinks. After completing initialization, the printer goes standby.

2. Auto-recovery error

● Temperature error

The print head temperature is increased when heavy-duty printing is continuous. If the print head temperature exceeds 70 degrees C, operation of the print head is automatically stopped to prevent overheating. The status LED blinks and the printer goes OFFLINE. The printer resumes printing when the head temperature falls to 60 degrees C or lower.

● Paper empty

Detect the paper empty through near end sensor and paper empty sensor.

The status LED blinks at paper near end and keeps the printer ONLINE.

After the paper runs out and the printer detects paper empty, the status LED turns On and the printer goes OFFLINE.

● Print head open

When the print head is lifted up, the status LED turns ON and the printer goes OFF-LINE.

After closing the print head, the printer goes on standby.

3. Unrecoverable error

- Auto cutter lock
When the cutter is blocked by a paper jam, the status LED blinks.
Press the head open button to return the cutter to its home position.
If the cutter does not return, keep the print head closed and contact a local dealer.
- Voltage error
When the printer detects abnormal voltage, the printer blinks the LED and goes OFFLINE.
Check the power supply voltage and if the problem is not cleared, please contact a local dealer.

4. LED status

LED status ○/◎ : Turn ON red and green for 0.1sec ● : Turn OFF for 0.1sec

- No error signal is detected

Status	LED
Standby	ON (Green LED)
Initializing	◎●◎● (Green LED)

- Auto-recovery error

Status	LED
Temperature error(≧70°C or more)	○●○● (Red LED)
Detect near end	◎●◎● (Green LED)
Paper empty	ON (Red LED)
Print head open	ON (Red LED)

- Unrecoverable error

Status	LED
Auto cutter lock	○◎○◎ (Red and Green LED)
Upper limit voltage error (≧27.0V or higher)	○◎○◎ (Red and green LED)
Lower limit voltage error (≧18.0V or lower)	○◎○◎ (Red and green LED)

4- 8. Memory

(1) Structure of memory

Table1. Capacity

No	Memory	Size(Unit: Byte)
1	Input buffer	8,192
2	User memory	8,192
3	2D barcode (Option)	34,480

(2) Input buffer

Buffer memory stores input data from the interface.

(3) User memory

User memory is used to store external characters, download characters and bit images. Users are able to manipulate the area freely. Calculate the available memory size due to the limited amount of memory available.

If there is no available memory, erase the used memory to free up enough space.

(4) 2D barcode (option)

2D barcode printing is available as an option.

The 2D barcode is manipulated for editing and analysis of data within the assigned area. For detailed information, refer to **GS Q** command.

5. Bezel Module

There are 3 different Bezel Mode A,B and C.

Setting Bezel mode is to be referred with the subject on memory switch.

5- 1. Operating Mode

Bezel Mode	Functions
Commonly worked at Bezel Mode A & B	The length of printing ticket is set at 60mm. If the length of ticket (paper) after cutting the paper is specified less than 60mm, the printer automatically feeds the length to reach 60mm and execute full cut. Ex) If the setting length is 40mm, the printer feed 20mm more after printing the data. If the length of ticket is set beyond 60mm, the ticket length is adjusted as specified length and cutter mode is changed to partial cut.
Bezel Mode A	Once setting this mode, the printer prints the data on paper continuously. ESC v and GS a commands is allowed to detect the information of existing (passing) paper in the bezel through equipped reflective sensor. But it is not enabled to stop the paper by this reflective sensor.
Bezel Mode B	This mode is enabled to stop the each ticket (paper). Without taking out the ticket from the bezel, the printer does not print next ticket. When the printer receives next printing data but nobody does not take the ticket, such next data are ignored. ESC v , GS R1 or GS a command is allowed to check the status of existing paper in the bezel.
Bezel Mode C	This function is basically worked for the same as Bezel Mode-A but This mode is not performed to adjust the paper length commonly worked at Mode A/B. The full cut is performed at this mode.

6. Presenter

The details please refer to the separate document "product specifications".

In this chapter, explain operating mode regarding a presenter function.

Setting operating mode is to be referred with the subject on "4-5.Memory switch setting menu".

6- 1. Specifications

- Available for three operating mode (Clamp mode/Retract mode/Eject mode &Continuous mode)
- Maximum 250mm for Paper issuing length.
- Maximum 240mm/sec for Paper issuing speed.
- Equip reflection-type photo sensor to detect paper.
- Maximum100um (85g/m2) for loading paper thickness.

6- 2. Operating Mode

(1) Clamp / Retraction Mode / Eject Mode

During printing and feeding, Paper automatically feed out synchronized while the paper is caught by clamp mode. After that, the paper is removed over the time-out by retraction mode or eject mode.

The timing chart is shown as below.

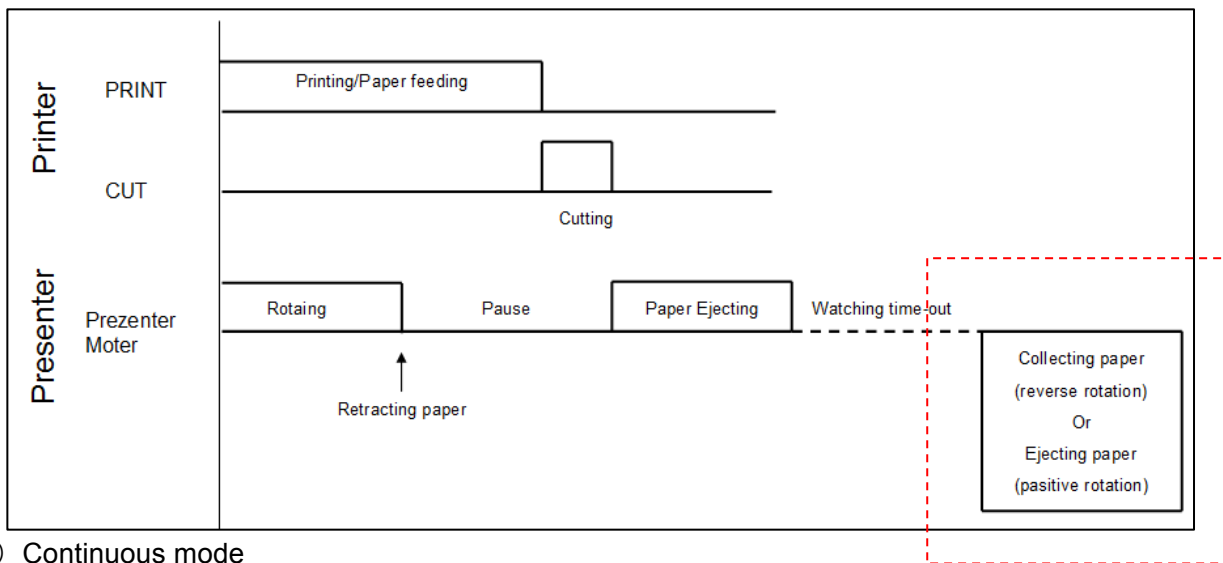

(2) Continuous mode

Presenter is continued to feed synchronized with cutting by Continuous mode.

This mode is recommended if 250mm paper is over. Timing Chart is shown as below.

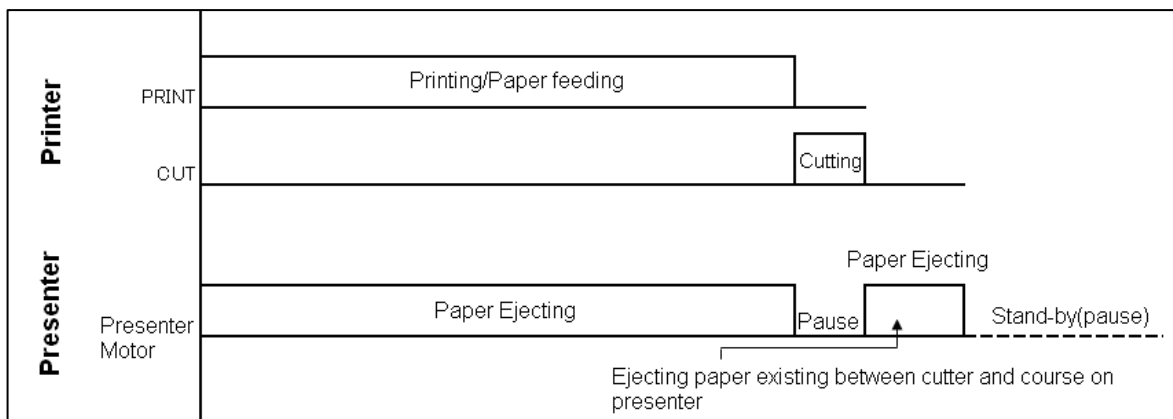

(3) The other specification

Specifications	Contents
Paper feed calibration	When receipt length is less than 50mm. Cutting is worked with calibrating automatically to length more than 50mm.
Cutting	Cutting is operated by changing partial-cut to full-cut.
Waiting for removing paper	After cutting, issuing is stopped until paper is removed. Status of paper can be read by a status command.

6-3. Stock space and Exit space

- ※1. Allow stock space for paper roll in accordance with the paper length of printing.
The height of stock space is to be more than 1/2 of the paper length.
- ※2. For retraction of printed papers, place the retraction box at the exit of printed papers.
The box height is to be 1.5 times more than the paper length.

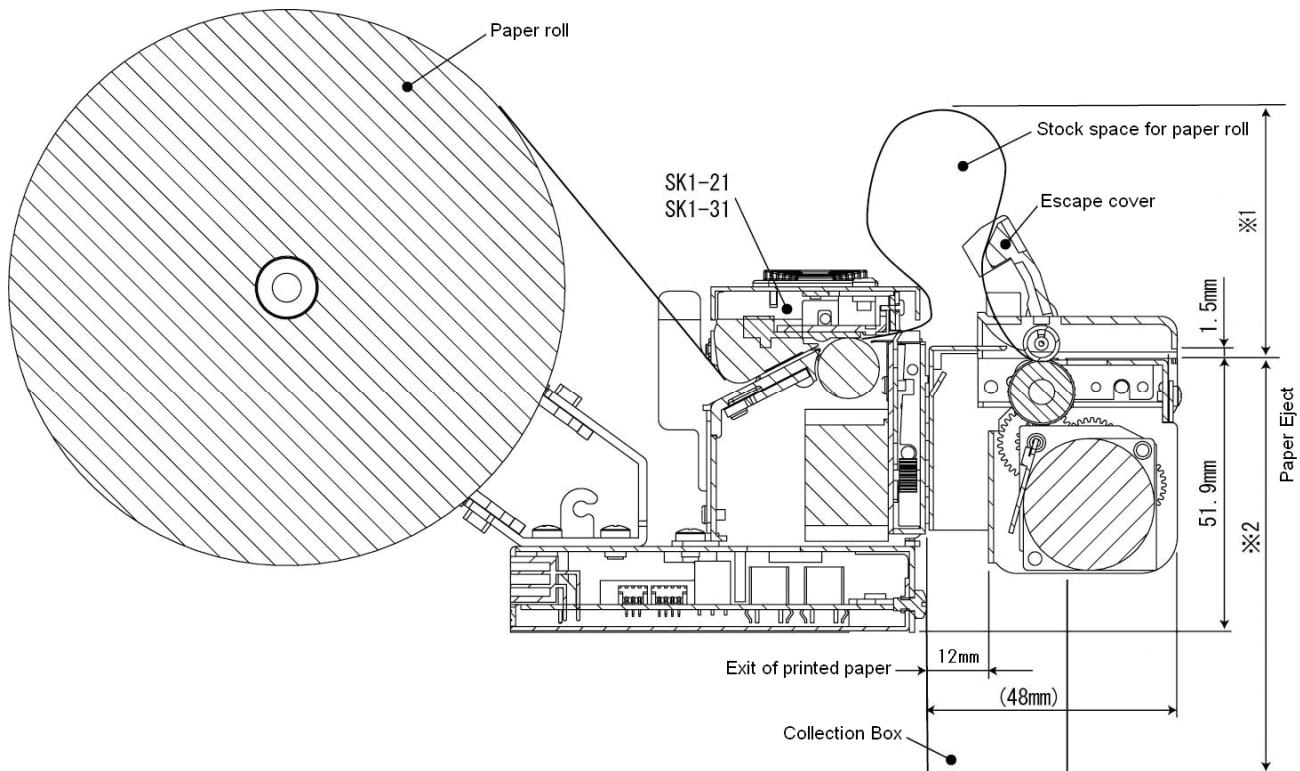

7. Interfaces

7-1. USB

(1) Pin layout

Connector: Mini-B type 5-PIN

This printer is equipped with USB version 2.0 for high speed data transfer.
The device class is "Printing Device."



Pin	Signal	Direction	Function
1	VBUS	-	Detect connect/disconnect of USB
2	D-	I/O	USB data (-)
3	D+	I/O	USB data (+)
4	N.C		
5	GND	-	GND

(2) Electronic characteristic

Parameter	Signal	Conditions	Min.	Max.	Unit
(Power supply voltage)					
	VBUS		4.40	5.25	V
(Input level)					
Differential input sensitivity	VDI	$ (D+)-(D-) $	0.2		V
Differential common mode range	VCM	Including VDI	0.8	2.5	V
Single end receiver threshold	VSE		0.8	2.0	V
(Output level)					
"L"Level	VOL	RL of 1.5kΩ to 3.6V		0.3	V
"H"Level	VOH	RL of 15kΩ to GND	2.8	3.6	V

7-2. Serial

(1) Pin layout

Connector: MIL-C-83503 (10pin MIL Standard)
Cvilux CH87102HA00 or equivalent
Recommendable plug
Cvilux CA2110SA1A0
Hirose HIF3BA-10D-2.54R
Amp 1658621-1 or equivalent socket

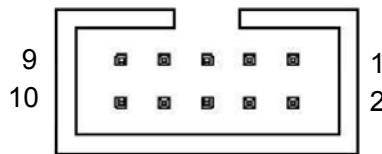

Pin	Signal	Direction	Function
1	N.C	---	
2	DTR	---	DSR loop connect
3	RxD	Input	Serial data input
4	RTS	Output	Request to send
5	TxD	Output	Serial data output
6	CTS	Input	Clear to send
7	DSR	---	DTR loop connect
8	N.C	---	
9	GND	---	
10	N.C	---	

DTR is used to control data transmission to some host systems.
When the host system is communicated by DTR, use loop connect of the host system.

(2) Conditions

Baud rate: 1200 to 115200bps
Parity: None, Odd, Even
Bit length: 7, 8 bit
Busy control: Hardware control(RTS/CTS/Software control(XON/XOFF))

(3) Hardware control

High/Low of RTS signal is used to control data transmission to the host system.

RTS signal becomes low if the receiving buffer is filled out curtain level (①)

The host side should stop sending data if RTS signal is low. If the data in the input buffer is reduced to curtain level, RTS signal goes high and re-start sending remained data (②)

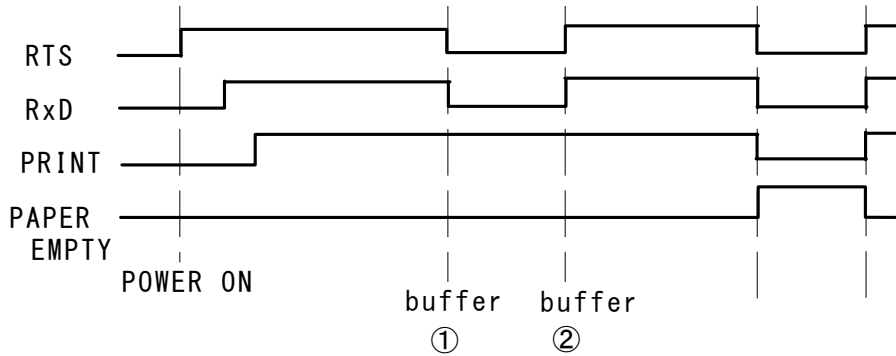

(4) Software control(XON/XOFF)

Xon(11H)/Xoff(13H) signal is used to control data transmission to the host system.

Xoff signal is sent to host system if the receiving buffer is filled out curtain level.(①)

The host side should stop sending data if Xoff signal is received. If the data in the input buffer is reduced to curtain level, Xon signal is sent to the host system and re-start sending remained data (②)

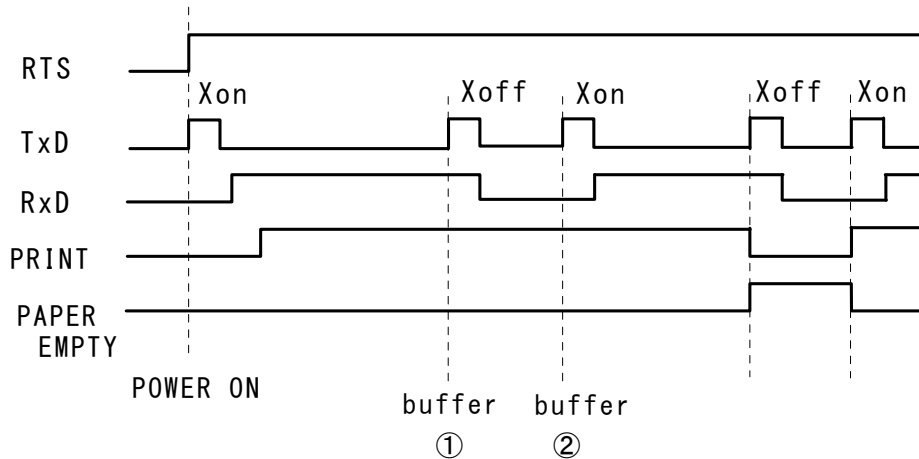

(5) Conditions of input / output signal

Item	Condition	Rate value			Unit
		Min.	Typ.	Max.	
High input voltage	RxD、CTS	+2.8	—	+15	V
Low input voltage	RxD、CTS	-15	—	-2.8	V
High output voltage	TxD、RTS (RL=3KΩ)	+2.8	—	+15	V
Low output voltage	TxD、RTS (RL=3KΩ)	-15	—	-2.8	V

7-3. Power supply

(1) Pin layout

Connector : Hirose DF1BZ-4P-2.5DS or equivalent

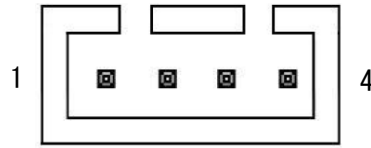

Pin	Signal	Direction	Function
1	DC+	—	Power supply (+)
2			
3	DC-	—	Power supply (-)
4			

※Depending on printing data, large peak current runs in the power cable.
Consider the voltage drop caused by cable impedance and allow enough margin when choosing the power cable.

8. Label print

There is the label mode to print the label paper and the receipt paper with black mark. Optional gap sensor (Transparent photo interrupter) and black mark sensor (Reflective photo interrupter) are sensed to top of label form.

(1) Set up label printing

1. Set COMMON SETTING in the memory switch. (Refer to IV-5 Memory switch)
 - Select the type of sensor by SELECT SENSOR.
 - Enable MARKING DETECTION
 - Enable MARK RE-DETECTION
2. Set the default value of initial printing information by DC2 L command.
The information includes label length, gap, stopping position after printing label and top of form.
3. Sensitivity of embedded sensor is changed by the DC2 mrk command.
Adjust sensitivity according to labels. (Refer to command reference I-16)
4. Press FEED button or send DC2 B、 DC2 I when the sensor is enabled to re-detect marking position after replacing the paper or turn the printer power ON.
5. The sensor is detected as paper empty if marking width is beyond 8mm.
6. Command for labels are listed in “Command Reference I -16. Label”

(2) Label mode

There are intermittent label mode and continuous label mode installed in the printer.

1. Intermittent label mode

Feed each label to the position of the paper cutter. The printer prints the next label after back feeding the label. This mode is useful to remove each label by each print.

Always retain the base paper. If the base paper is cut and the distance between edge of the base paper and the front of the label becomes shorter than 15mm, the label paper is peeled off while back feeding.

Note1. Adjust the cut position by command **DC2 L**.

Note2. Set the amount of back feed not beyond back feeding limit and DC2 L n3.

Note3. Thickness and length of labels and base papers may cause unexpected results during back feeding. Please make sure the label paper works for back feeding.

2. Continuous label mode

Prints each label continuously without back feed when label paper cannot be fed to the correct cutter position or it is hard to cut the label at the stopped position.

It is recommended to choose this mode when the height of the label is relatively short or back feeding cannot be performed.

Refer to the command setting for DC2 L / n3、 n4 parameter 0.

(3) Setting the media

Peel off labels within 15mm from the end of the media and set the end emerging 10mm from the cutter. This prevents the label from sticking inside of the printer.

(4) Receipt paper with black mark

Recommend designing black marks on the receipt as shown in below.
No gap type continuous label should use the same design.

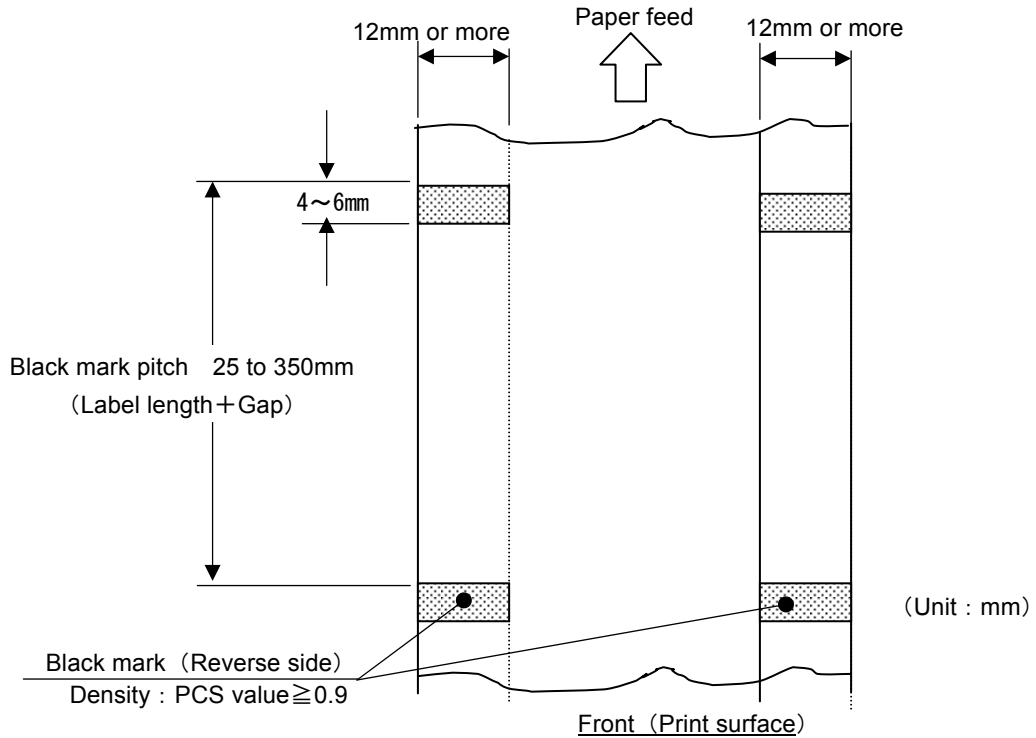

	<ul style="list-style-type: none">• If PCS of black marks is less than 0.9, black marks are not sensed and the page might be skipped or the right length not detected. It causes the failure of sensing.• Prohibit pre-printing in the area designated for black marks.• There is a feed tolerance $\pm 2\%$ between calculated value and actual length. Please take into account this tolerance when pre-printed paper is used.
--	---

※ The position of black mark is decided by that of black mark.

※ When 58mm/60mm width paper is used, the black mark sensor is installed on left side.

(5) Label specifications

SK1-31 prints label paper with black marks and without black marks.

Use label paper complying with the following conditions.

Item	No black mark	With black mark
Recommendable media	HW76B (Nippon Paper Ind.) Length: 94μm Thickness of base paper: 60μm Color on base paper: White Total thickness: 154μm or less (incl. adhesive)	
Roll diameter	Φ120mm or less	
Label core	Φ25.4 (Internal dia.) × Φ31.4 (External dia.) mm	
Base paper width	57.5±0.5mm / 59.5±0.5mm / 79.5±0.5mm	
Label width	54±0.5mm / 56±0.5mm / 76±0.5mm	
Length	25 to 350mm	
Label gap	3 to 6mm	0 to 6mm
Rolling up direction	Label surface is outside of a roll	
Black mark size	—	Width : 12mm or more Length : 4 to 6mm
Density of black mark	—	Ink : Reflective ratio should be 7% or less.

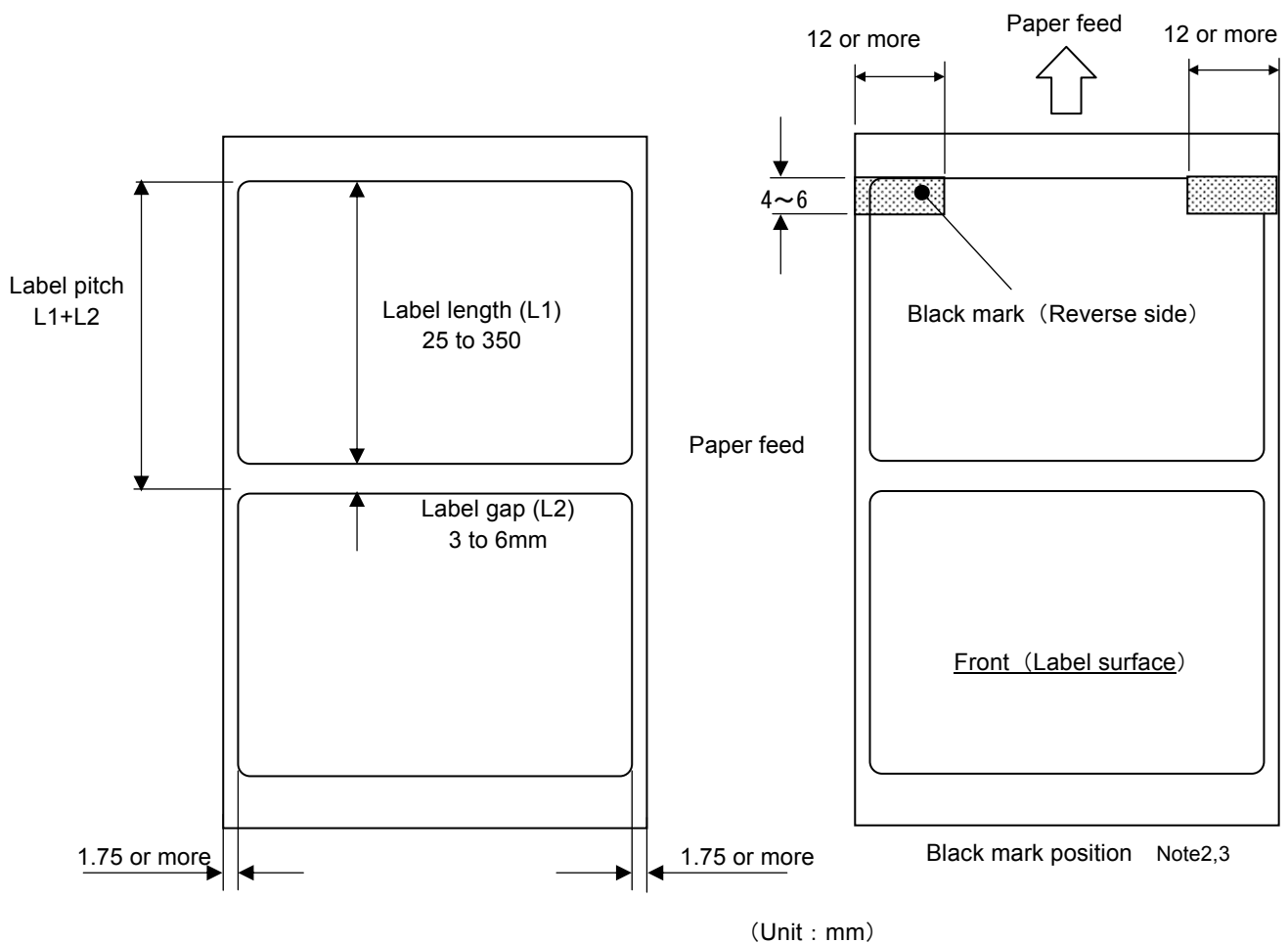

Note 1. Above illustration shows the paper width 80.0mm..

Note 2. The position of black mark is decided by that of black mark.

Note 3. When 58mm / 60mm width paper is used, the black mark sensor must be installed on left side.

(6) Printing area

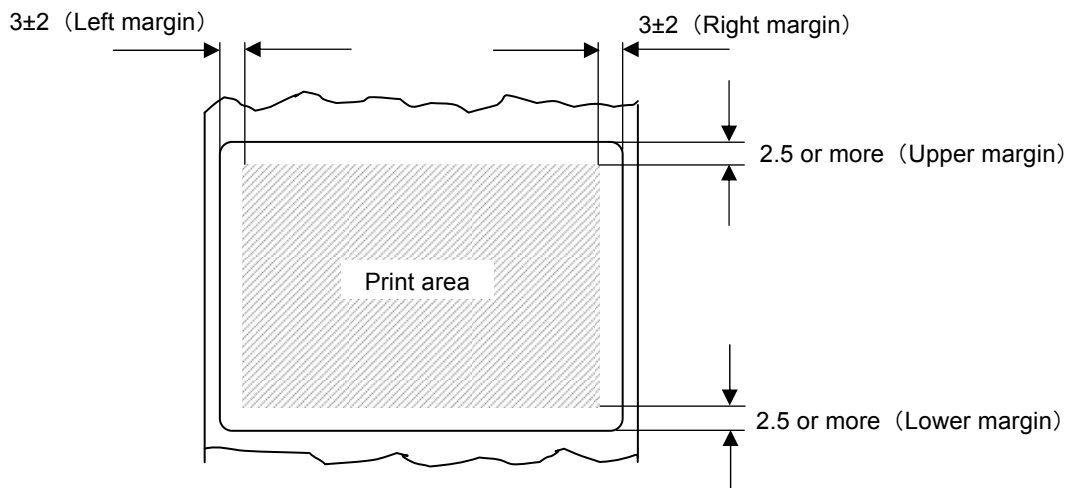

(Unit : mm)



- The tolerance of the embedded sensor and initial printing position varies about ± 2 mm from calculated position.
- Take into account the tolerance of paper feed about $\pm 2\%$ when a label is designed.

9. Maintenance

9- 1. Maintenance

Periodically clean the printer to maintain the printing quality and avoid failures. It is recommended to maintain the printer every 6 months or 1 million lines of printing.

(1) Print head

When cleaning the thermal dot line on the print head, use a cotton swab with alcohol (ethanol, methanol or Isopropyl alcohol) and wipe off stains and dust.

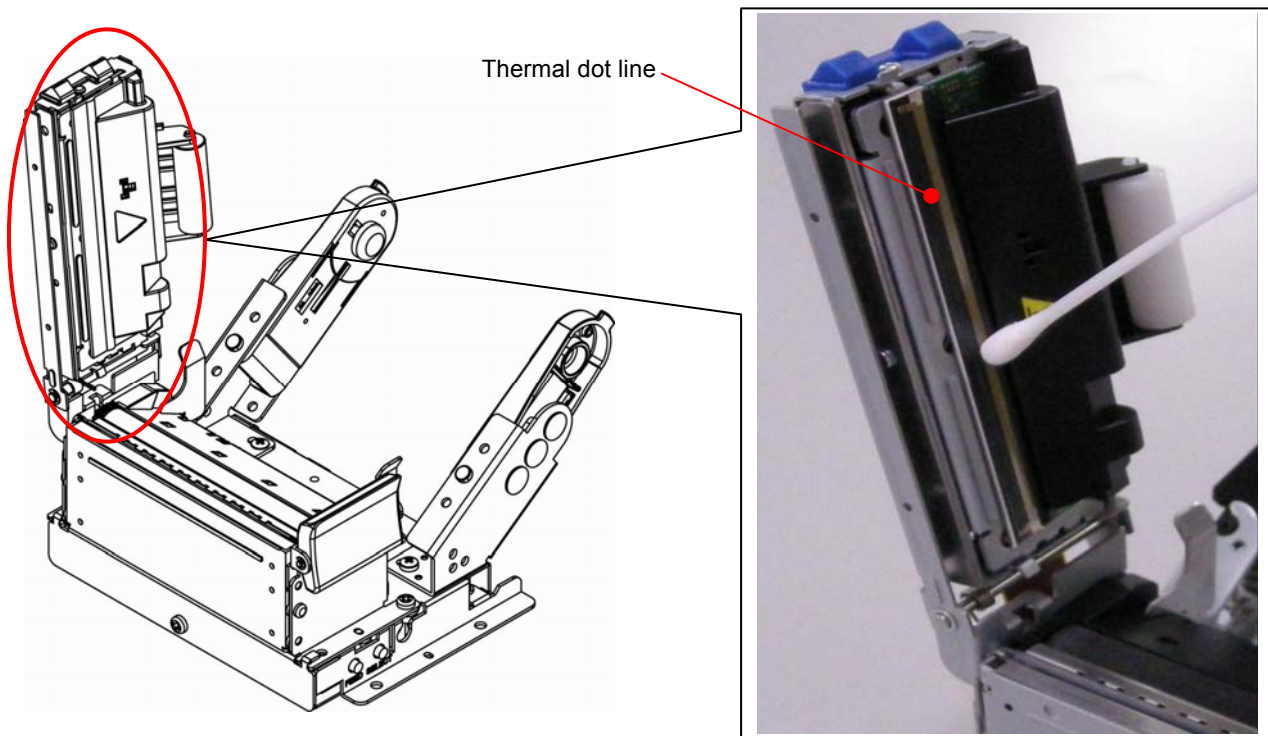

(2) Platen roller

When cleaning the platen roller, use a dry soft cloth and wipe off the stain with rotating the roller.

(3) Sensor and peripherals

Clean the stain, dust and paper powder on the paper empty sensor and paper cover sensor.



- Prior to maintenance work, be sure to turn OFF the printer.
- Avoid cleaning the print head immediately because the print head is hot. Start maintenance work after the thermal head becomes cool.
- Do not touch the print head with fingers directly. It may cause damage by electrostatic discharge and contamination.
- Do not touch the thermal head dot line with bare hands or metal objects.
- Do not use volatile chemical agents, such as thinner and benzene.
- Do not get moisture or spill liquids inside of the printer.
- Turn ON the printer only after alcohol is completely dried.

9- 2. Service for trouble shooting

For maintenance and service, please contact your Sanei local distributors or the following address.

Sanei Electric Inc.

Overseas sales division

2-61-1 Ikebukuro, Toshima-Ku, Tokyo 171-0014, Japan

TEL: 81-3-3986-1188

FAX: 81-3-3988-5876

www.sanei-elec.co.jp

10. Command systems

Command systems are compatible with ESC/POS.

The details please refer to separate volume “command reference”.

10- 1. Command table

1. Paper feed command

Command	Standard mode	Page mode
CR	Carriage return / Line feed	Retrieve page memory / Carriage return
LF	Carriage return / Line feed	Retrieve page memory / Carriage return
FF	Page length printing	Printing in page mode and returning to standard mode
ESC C	Set the page length	(Setting only)
ESC J	Printing and feed forward	Move Y axis in the forward direction
ESC j	Printing and back feed	Move Y axis in the backward direction
ESC d	Printing and consecutive line feed	Consecutive line feed

2. Tab command

Command	Standard mode	Page mode
HT	Horizontal tab	
ESC D	Set horizontal tab	

3. Format command

Command	Standard mode	Page mode
ESC 2	Set the initial linefeed value	
ESC 3	Set the linefeed value	
ESC SP	Set the right margin	
GS L	Set the left margin	(Setting only)
GS W	Set the printing area width	(Setting only)
ESC \$	Set absolute position of the Printing area	(Setting only)
ESC a	Align the position	

4. Character modification command

Command	Standard mode	Page mode
ESC !	Modify character specifications in a batch	
ESC G	Specify the bold character / cancel	
ESC E		
ESC {	Specify inverse printing / cancel	Specify inverse printing / cancel
ESC -	Specify underline / cancel	
GS !	Set a character size	
GS B	Specify the black and white reverse character / cancel	
GS b	Specify and Cancel a smoothing font	

5. Character Selection Command

Command	Standard mode	Page mode
ESC M	Choose a character font	
ESC R	Choose an international character	
ESC t	Choose the character code table	
ESC &	Register a download character	
ESC ?	Erase a download character	
ESC %	Specify and cancel a download character	

6. Bit Image Command

Command	Standard mode	Page mode
ESC *	Specify the bit image	
GS *	Register the downloaded bit image	
GS /	Print the download bit image	
DC2 V	Specify the high-speed bit image	
DC2 v	Print pressed raster bit image	
ESC b	Specify the high-speed bit image with indicated printing width	

7. Page Mode Command

Command	Standard mode	Page mode
ESC L	Select the page mode	(Invalid)
ESC S	(Invalid)	Select the standard mode
ESC FF	(Invalid)	Print all page mode memories.
CAN	Erase the print buffer	Clear page mode memories
ESC T	(Invalid)	Select printing direction and initial position
ESC W	(Invalid)	Defining the print area

8. Peripheral Equipment Command

Command	Standard mode	Page mode
ESC =	Select peripheral	
ESC c 3	Select paper sensor to output PE signal	
ESC c 5	Specify or cancel panel switch	
ESC c 6	Enable / Disable paper loading	
ESC i	Full cut	
ESC m	Partial cut	
GS V	Paper cut	

9. Response Command (Installed in Serial interface)

Command	Standard mode	Page mode
GS a	Valid / Invalid of automatic status transmission	
GS r	Transmit status	
GS DLE	Valid/Invalid of real-time status transmission	
GS EOT	Transmit status in real-time	
GS E	Answer the string	
GS R1	Check printer status	
GS R 3	Print start /cut end automatic status transmission	
GS I	Send printer ID	
ESC s	Send a printer information	
ESC v	Send a printer status in the present	

10. Printing Image Registration Command

Command	Standard mode	Page mode
FS Q	Specification of image registration onto the nonvolatile memory	
FS R	Cancel Image registration in the nonvolatile memory	
FS O	Set printing image registered in the nonvolatile memory	
FS P	Cancel printing image registered in the nonvolatile memory	

11. Ruled Line Command

Command	Standard mode	Page mode
DC3 A	Choose ruled line buffer A	
DC3 B	Choose ruled line buffer B	
DC3 C	Clear the ruled line buffer	
DC3 D	Write dot specification to the ruled line buffer	
DC3 L	Write line specification of the ruled line buffer	
DC3 +	Enable the ruled line printing mode	
DC3 -	Disable the ruled line printing mode	
DC3 P	Execute printing of 1 dot ruled line	

12. Function Setting Command

Command	Standard mode	Page mode
ESC @	Initialization	
DC2 D	Reserve and release a download character registration area	
DC2 G	Reserve and release a user-defined character registration area	
DC2 ~	Set printing density	
GS (A	Self test print	
DC1	Software reset	
DC2 R	Read a software memory switch	
GS G	Specify the stored buffering mode / cancel	
DC2 K	Set the memory switch	

13. Barcode Command

Command	Standard mode	Page mode
GS H	Set the HRI character printing	
GS h	Set the barcode height	
GS w	Set the barcode width	
GS k	Print barcode	

14. 2D Barcode Command (OPTION)

Command	Standard mode	Page mode
GS Q	Print two dimensional barcode (PDF417, MicroPDF417, DataMatrix, MaxiCode, QRCode)	
GS S	Change the cell size of two dimensional barcode	

15. Label Command

Command	Standard mode	Page mode
DC2 L	Set the length of label	
DC2 I	Label feed	
DC2 B	Re-detect of marking position	
DC2 mrk	Set the marking threshold	

16. Presenter Command

Command	Standard mode	Page mode
ESC h	Select the active mode on the presenter	
ESC r 0	Select the presenter operation	
ESC r 1	Set the time-out for the retractive mode.	
ESC r 3	Select the presenter mode	
ESC r @	Reset of the presenter error factor	

10-2. Data code table

PC437

High-order bit \ Low-order bit		0	1	2	3	4	5	6	7	8	9
		0000	0001	0010	0011	0100	0101	0110	0111	1000	1001
0	0000		DLE	SP	0	@	P	'	p	Ç	É
1	0001			!	1	A	Q	a	q	ü	æ
2	0010		DC2	"	2	B	R	b	r	é	Æ
3	0011		DC3	#	3	C	S	c	s	â	ô
4	0100	EOT		\$	4	D	T	d	t	ä	ö
5	0101	ENQ		%	5	E	U	e	u	à	ò
6	0110			&	6	F	V	f	v	á	û
7	0111			'	7	G	W	g	w	ç	ù
8	1000		CAN	(8	H	X	h	x	ê	ÿ
9	1001	HT)	9	I	Y	i	y	ë	ÿ
A	1010	LF		*	:	J	Z	j	z	è	Ü
B	1011		ESC	+	:	K	[k	{	ï	ƒ
C	1100	FF	FS	,	<	L	\	l		î	€
D	1101	CR	GS	-	=	M]	m	}	ì	¥
E	1110			.	>	N	^	n	~	À	Ŕ
F	1111			/	?	O	_	o	SP	Á	f

High-order bit \ Low-order bit		A	B	C	D	E	F
		1010	1011	1100	1101	1110	1111
0	0000	á	⌘	⌘	⌘	α	≡
1	0001	í	⌘	⌘	⌘	β	±
2	0010	ó	⌘	⌘	⌘	Γ	≥
3	0011	ú	⌘	⌘	⌘	π	≤
4	0100	ñ	⌘	⌘	⌘	Σ	∫
5	0101	Ñ	⌘	⌘	⌘	σ	∫
6	0110	â	⌘	⌘	⌘	μ	÷
7	0111	â	⌘	⌘	⌘	τ	≈
8	1000	¿	⌘	⌘	⌘	φ	°
9	1001	⌘	⌘	⌘	⌘	θ	·
A	1010	⌘	⌘	⌘	⌘	Ω	-
B	1011	½	⌘	⌘	■	δ	√
C	1100	¼	⌘	⌘	■	∞	n
D	1101	¡	⌘	⌘	■	∅	²
E	1110	«	⌘	⌘	■	€	■
F	1111	»	⌘	⌘	■	∩	SP

- SP indicates space.
- A code in the blank section is ignored.
- The content in a bold frame is a function code.

Note: The character code table indicates bits arranged in the shape of a character and does not represent an actual printing pattern.

KATAKANA

High-order bit \ Low-order bit		0	1	2	3	4	5	6	7	8*	9*
		0000	0001	0010	0011	0100	0101	0110	0111	1000	1001
0	0000		DLE	SP	0	@	P	'	p	—	⊥
1	0001			!	1	A	Q	a	q	—	⊥
2	0010		DC2	"	2	B	R	b	r	—	⊥
3	0011		DC3	#	3	C	S	c	s	■	⊥
4	0100	EOT		\$	4	D	T	d	t	■	—
5	0101	ENQ		%	5	E	U	e	u	■	—
6	0110			&	6	F	V	f	v	■	
7	0111			'	7	G	W	g	w	■	
8	1000		CAN	(8	H	X	h	x		⌈
9	1001	HT)	9	I	Y	i	y		⌋
A	1010	LF		*	:	J	Z	j	z		⌌
B	1011		ESC	+	:	K	[k	{	■	⌍
C	1100	FF	FS	.	<	L	¥	l		■	⌎
D	1101	CR	GS	-	=	M]	m	}	■	⌏
E	1110			.	>	N	^	n	~	■	⌐
F	1111			/	?	O	_	o		+	⌑

High-order bit \ Low-order bit		A	B	C	D	E	F
		1010	1011	1100	1101	1110	1111
0	0000	SP	一	夕	ミ	≡	×
1	0001	。	ア	チ	ム	⌂	円
2	0010	「	イ	ツ	メ	≡	年
3	0011	」	ウ	テ	モ	≡	月
4	0100	、	エ	ト	ヤ	▲	日
5	0101	・	オ	ナ	ユ	▼	時
6	0110	ヲ	カ	ニ	ヨ	▼	分
7	0111	ヲ	キ	ヌ	ラ	▼	秒
8	1000	イ	ク	ネ	リ	♠	〒
9	1001	ウ	ケ	ノ	ル	♥	市
A	1010	エ	コ	ハ	レ	♦	区
B	1011	オ	サ	ヒ	ロ	♣	町
C	1100	カ	シ	フ	ワ	●	村
D	1101	ク	ス	ヘ	ン	○	人
E	1110	コ	セ	ホ	°	/	■
F	1111	ク	ソ	マ	°	\	

- SP indicates space.
- The code in the blank section is ignored.
- The content in a bold frame is a function code.

*A character in a row marked with * is not printed in the SHIFT JIS CODE.

High-order bit \ Low-order bit		0	1	2	3	4	5	6	7	8	9
		0000	0001	0010	0011	0100	0101	0110	0111	1000	1001
0	0000		DLE	SP	0	@	P	'	p	Ç	É
1	0001			!	1	A	Q	a	q	ü	æ
2	0010		DC2	"	2	B	R	b	r	é	Æ
3	0011		DC3	#	3	C	S	c	s	â	ô
4	0100	EOT		\$	4	D	T	d	t	ä	ö
5	0101	ENQ		%	5	E	U	e	u	à	ò
6	0110			&	6	F	V	f	v	á	û
7	0111			'	7	G	W	g	w	ç	ù
8	1000		CAN	(8	H	X	h	x	ê	ÿ
9	1001	HT)	9	I	Y	i	y	ë	ÿ
A	1010	LF		*	:	J	Z	j	z	è	Ü
B	1011		ESC	+	:	K	[k	{	ï	ø
C	1100	FF	FS	.	<	L	\	l		î	£
D	1101	CR	GS	-	=	M]	m	}	ì	Ø
E	1110			.	>	N	^	n	~	Ä	x
F	1111			/	?	O	_	o		Å	f

High-order bit \ Low-order bit		A	B	C	D	E	F
		1010	1011	1100	1101	1110	1111
0	0000	á	☐	└	Đ	Ó	–
1	0001	í	☐	┘	Đ	β	±
2	0010	ó	☐	┘	Ê	Ô	≥
3	0011	ú		┘	Ê	Ò	¼
4	0100	ñ	┘	—	Ê	ó	¶
5	0101	Ñ	Á	+	€	Õ	§
6	0110	ª	À	á	í	μ	÷
7	0111	º	À	À	í	þ	¸
8	1000	¿	©	└	ÿ	þ	°
9	1001	®	┘	┘	┘	Ú	”
A	1010	¬		┘	┘	Û	•
B	1011	½	┘	┘	■	Ü	¹
C	1100	¼	┘	┘	■	Ý	³
D	1101	¡	┘	—		Ý	²
E	1110	«	┘	+		-	■
F	1111	»	┘	α	■	´	

- SP indicates space.
- A code in the blank section is ignored.
- The content in a bold frame is a function code

Note: The character code table indicates bits arranged in the shape of a character and does not represent an actual printing pattern.